

PHILIPS

APPLICATION BOOK

ELECTRONIC COMPONENTS
AND MATERIALS DIVISION

BUILDING Hi-Fi SPEAKER SYSTEMS



Building Hi-Fi Speaker Systems



A selection of the high quality and high fidelity loudspeakers which are used to build the recommended systems.

Building Hi-Fi Speaker Systems

M. D. Hull., C. Eng., A.M.I.E.R.E.

and

K. R. de Vries

**PUBLICATIONS DEPARTMENT
ELECTRONIC COMPONENTS AND MATERIALS DIVISION**

© *N.V. Philips' Gloeilampenfabrieken*

EINDHOVEN - The Netherlands

First edition December 1969

Second edition June 1970

Third edition October 1970

*The publication of this document does not
imply a licence under any patent*

List of Contents

1	Introduction	1
2	High Fidelity Performance Requirements	2
2.1	The Illusion of High Fidelity	2
2.2	Sources of High Fidelity Sound	3
2.3	Sound Amplification	4
2.4	Stand By for Stereo	6
2.5	Loudness and Listening .	11
2.6	Scrapping the Whole Idea .	12
3	Loudspeakers for High Fidelity Reproduction	13
3.1	Speaker Specification	13
3.2	Bags of Bass	17
3.3	Simple Set-ups .	20
3.4	Multi-speaker Systems	22
3.5	Electrical Details of 14 Two-way Systems	29
3.6	Electrical Details of 10 Three-way Systems	43
4	Enclosures for High Fidelity Systems	53
4.1	Baffled	53
4.2	Vented Enclosures	53
4.3	Sealed Enclosures	54
5	Step-by-step Construction of a 7-litre Enclosure	63
6	Constructional Details of 24 Speaker Systems	73
7	Listening Room Acoustics	88
7.1	Absorption and Reverberation	88
7.2	Room Resonances	88
7.3	Positioning of Speakers	89
7.4	Blaming Your Speaker	89
7.5	The Latest thing in Sound — Mono	91
7.6	Psychedelic Sound and the Future	92
	Appendix 1 — Cross-over Filter Components	95
	Appendix 2 — Speaker Dimensions and Response Curves	97

The loudspeaker systems described in this book are proven designs and we regret that we cannot undertake to answer queries from home-constructors arising from the information presented.

Acknowledgements

Acknowledgements are made to members of the Staff of the Loudspeaker Development Laboratory, and particularly J. Vandekerckhove, for their valuable assistance in making data available to the authors and preparing numerous response curves for publication in this book

Foreword

This book is about our high fidelity range of loudspeakers; how to choose them, and how to use them.

Our *high fidelity* range consists of 28 different types of speakers specifically designed to meet the stringent requirements for high fidelity sound reproduction, in addition to the 127 different types of speakers of our *standard range* which are used mainly in radio and TV sets, inexpensive tape recorders and record players.

Although this book is written primarily for the hi-fi enthusiast who wishes to build his own speaker enclosures, the needs of those who simply wish to improve the sound quality of a radio, TV set, or record player are well catered for. An easy-to-read style has been adopted, therefore, in harmony with the recreative atmosphere surrounding the pleasures of hi-fi, and no attempt has been made to produce a textbook. An elementary knowledge of the principles of sound reproduction is assumed. The reader is given guidance on choosing the best speaker for his needs, together with constructional information for building suitable enclosures.

The book may also be of interest to manufacturers who wish to produce high fidelity loudspeaker enclosures. Details of 24 different speaker systems have been included and these cover a wide range of output powers with different frequency responses.

We promise the reader an exciting and fulfilling time in building his own enclosures — there can never be a sweeter sound, even with 10% distortion!

M.D.H.
K.R.d.V.

Foreword to the Third Edition

A number of changes have been made since this book was first published. First of all, in the second edition we decided to increase the distance between the grille cloth and the speakers to give more space for the forward movement of the cone at maximum power output. The volumes of the recommended enclosures were not affected in any way by this change and the only obvious difference in appearance was an increase of 1 cm in the overall depth.

The most significant alterations in this edition are those made to the cross-over filters. The polarity of the mid-range speakers has been reversed in all the *three-way systems*, and details of winding the filter coils are given in an extra Appendix.

Changes in speaker phasing were made necessary because of a number of conflicting reports on performance. The filters were originally designed and tested with the woofers and mid-range speakers mounted behind the baffle board; the conventional way. We knew that most constructors would find it more satisfactory to mount them on the front, so we set the trend and moved the woofers and the mid-range speakers to the front of the baffle. In some cases we shifted the speakers by as much as 25 mm through the thickness of the baffle board and that distance is nearly an extra quarter of a wavelength at 3000 Hz. This frequency is one of the cross-over frequencies and it meant that cancellation of sound output could occur at the baffle board around cross-over frequency due to anti-phase conditions in the radiated sound. We have thus changed over the connections to the mid-range speakers. But the constructor must try it out for himself; the final result depends upon the distances apart of the speakers and the frequency. And the effect can be different with different enclosures. The polarities given in the circuits now represent what we believe will give the best results but, if the mid-range speaker does not appear sufficiently effective, the connections to it should be reversed.

Many manufacturers are now moving over to front mounting all their speakers. It is necessary that they determine very carefully the polarity of the mid-range speakers, otherwise it may not be considered worthwhile buying a three-way system. The final test is a listening test. The previous

method of connecting the mid-range speaker will no longer be necessarily correct because the baffle board thickness is now of no consequence in this respect.

We have had a number of requests for coil winding data from constructors who cannot easily obtain the inductors for the cross-over filters. A new Appendix has been included in this edition, therefore, which gives bobbin sizes and numbers of turns for all the inductors specified in this book. Ferrite rods and “C-cores” can obviously be used to reduce the sizes of some of the larger coils but we decided, after some deliberation, to give the data for air-cored coils only, and leave it to the ingenuity of the constructor to reduce their physical size, if he so desires, in his own way. Data is also given on the filter capacitors. Interested readers will welcome the new Application Book “Audio Amplifier Systems”, just published. It contains over 30 practical circuits and constructional data is provided for many of them. Of special importance to those wishing to know about the design of sealed enclosures is a complete Chapter, providing a more technical treatment of the subject, devoted to loud-speaker systems.

M.D.H.
K.R.d.V.

1 Introduction

This book is directed at the reader who wishes to build his own loud-speaker system. Whilst other designs for speaker systems give exact dimensions for the materials to be used and in this way restrict the constructor to a fixed size of enclosure, those recommended in this book are much more flexible, only the volume of the enclosure being given, and the actual dimensions are left to the discretion of the constructor.

This system of building a speaker enclosure will greatly appeal to all hi-fi enthusiasts because the shape of the cabinet can be made to suit different conditions of installation, such as wall-mounting, bookshelf arrangements, and so on. No longer will it be necessary to occupy valuable floor-space in the living room by an enclosure that is so cumbersome it has to stand on the floor.

The loudspeaker has the very exacting task of converting the electrical signals from the power amplifier back into a faithful reproduction of the original sound but, only too often, insufficient attention is given to it. The rest of the equipment in the reproduction chain counts for little if the speaker is inadequate, whereas the sound quality of even the cheapest tape recorder can be greatly improved when reproduced through a good quality loudspeaker system.

The performance of the loudspeaker, depends very largely on the enclosure, and it is vitally important that the loudspeaker is housed in a proper cabinet. To fit a loudspeaker in any old box and then expect it to give superb performance is very unfair and little short of inexcusable. Where the enclosure is a bass-reflex type, it may well need tuning to give satisfactory performance and the constructor rarely has the instruments to do this. The more popular enclosures of today are sealed boxes, and much smaller than the bass-reflex for the same performance, but it is not easy to achieve acceptable results unless the enclosure was designed by the manufacturer of the speaker with which it is to be used.

Before choosing a speaker and a suitable enclosure a number of factors have to be considered. This book discusses these points in simple terms and provides the reader with sufficient information on which to base his choice.

2 High Fidelity Performance Requirements

2.1 The Illusion of High Fidelity

From the earliest days of the gramophone enthusiasts have talked about the *fidelity* or *faithfulness* of reproduction made possible by every technological advance. The use of the term *high fidelity* to describe everything from cosmetics to ball-bearings, which appears to happen nowadays, makes enthusiasts even more critical of sound installations than ever before. High fidelity is a term which can be defined by reference to all kinds of graphs and specifications and by this method one can measure how “hi” one’s “fi” really is. But for the benefit of the listener whose pleasure is derived from listening to beautiful sounds we would prefer to describe high fidelity as realistic sound reproduction with the best equipment currently available.

We can never expect complete fidelity of the original sound of a large orchestra when we reproduce it at home; unless we happen to live in a concert hall, of course. The best we can do, nevertheless, is to enjoy a pleasing impression of the original sound, presented in a manner to suit the surroundings of our living room. Generally, the better the equipment the higher the cost. Good equipment costs money, every little part of it right throughout the reproduction chain. But money can be so easily wasted, particularly if one is under the impression that high fidelity reproduction can be obtained with all the gear mounted in one piece of furniture. Unless the equipment is mounted in a housing where speaker vibrations can be *completely* isolated from the sensitive parts of the system, such as the pick-up cartridge, separate speakers *must* be used.

The various parts of a high fidelity installation — amplifiers, pick-ups, loudspeakers, and so on — are sold separately for the enthusiast to incorporate into his own installation. This means, of course, that a minimum of two items of furniture are needed and the loudspeaker is one of them. For stereo installations at least three items are required. A large installation could easily consist of a tuner unit, a tape recorder, a pick-up and turntable, a control unit and two power amplifiers — plus the speakers.

From the foregoing it should be realised that one simply cannot afford to throw money away and investment in a really good quality loudspeaker will smooth the path of the enthusiast. It should also be remembered that

good quality mono is infinitely superior to poor quality stereo, and is considerably cheaper. This book offers guidance on what to expect, what is required, and what can be achieved to create the illusion of high fidelity.

2.2 Sources of High Fidelity Sound

Four high-quality sound sources exist for domestic sound: disc, magnetic tape, VHF FM radio, and television sound.

There appears to be every reason why we should now give the frequency range of each of these sources of programme material and say that all that has to be done is to make sure that the complete installation is capable of passing them through to the speaker without adding to them or taking anything away. Certainly this approach to sound reproduction is possible, but not for high fidelity.

A musical note consists of a *fundamental* tone with a certain frequency of vibration, accompanied by a series of *harmonics*, each of which is a multiple of the fundamental frequency. The amount of sound energy which each harmonic contains depends on the type of instrument which produces the sound and this is what distinguishes one instrument from another. In music, frequency is referred to as *pitch*, whereas the character of a sound, which depends on the proportion of harmonics it contains, is known as *timbre*. Harmonics are sometimes called *overtones*. The highest fundamental frequency that a cello will produce is around 700 Hz, but the harmonic content of its music extends to around 20 000 Hz. If the frequency response of the sound installation is limited to about 700 Hz, then cello music one will have, but it will never *sound* like a cello because its harmonics will not be reproduced. Limit the frequency response of the system to around 400 Hz and everything will sound like a tuba — a tuba without its harmonics, that is!

For these reasons we believe that to measure one's hi-fi requirements by means of a lot of misleading figures, such as a frequency chart for sources of sound, will only result in dissatisfaction and, unless the enthusiast is addicted to tubas, we recommend that he aims for a much wider frequency range of reproduction. The question is what?

Fortunately, thousands of listening tests have been carried out by manufacturers of sound equipment all over the world and, although individual opinions vary, and always will, as to what constitutes hi-fi reproduction, it has generally been agreed to accept a frequency range of 40 to 20 000 Hz as a suitable compromise. Naturally, every frequency in this

range must be reproduced without any noticeable distortion — there will always be some distortion, but if we cannot hear it, who cares?

From the foregoing the enthusiast will realise that if it is high fidelity reproduction that he wants he must select a loudspeaker with a frequency range equal to, or better than, the rest of his installation. Otherwise, why spend the money on the electronics? The nature of the sound source has really very little to do with his choice, because versatility on the input side of things is one of the most important features of most hi-fi set-ups, and, provided that reproduction is possible over the frequency range 40 to 20 000 Hz without noticeable distortion, loudspeaker included, then that is hi-fi.

We should mention that not all people are capable of hearing frequencies up to 20 000 Hz, only children, in fact. But if you think that money can be saved by lowering your sights a little and settling for an installation that will give good reproduction up to 10 000 Hz — STOP! Sounds of a transient nature such as those produced by a piano, drums and cymbals must be reproduced in a crisp and life-like manner and they will only sound that way if the frequency response of the complete installation is wide enough to handle them.

Mathematically, it can be shown that all waveforms can be broken down into a combination of sine waves consisting of a fundamental frequency and various harmonics of that fundamental. The sharper the rise of the waveform, the higher will be the frequencies of the harmonics. A sudden crash of the cymbals produces a very steep-fronted waveform and if the hi-fi installation cannot handle those frequencies without distortion or loss, then the music will lack punch, or “attack”

We are sorry that there is no short cut to high fidelity, so settle for a frequency range of 40 to 20 000 Hz for your installation, especially where the speaker is concerned.

2.3 Sound Amplification

Looking only at the electronics for a moment, a few words of caution would appear timely. If the enthusiast possesses a tube amplifier it will, almost certainly, have an output transformer which provides the current to drive the loudspeaker. This has an output impedance of so many ohms and it is essential that the combined load which any number of speakers presents to the output transformer is the same number of ohms. This principle also applies where the enthusiast has a transistor amplifier, but

here the chances are that the output transformer has been dispensed with. When a tube amplifier is working into a load which is the same as the output impedance of the amplifier, it is said to be correctly matched. Under these conditions maximum power will be transferred from the amplifier to the speaker with a minimum of distortion. If the loudspeaker has a lower impedance than the amplifier, the amplifier may be damaged.

Our loudspeaker impedances are standardized at 4 ohms, 8 ohms, 15 ohms and 25 ohms. There are also 800 ohm speakers for use with transformerless output stages of tube amplifiers.

Output transformers seem to have got a bad name. We do not really know why this should be, but we suspect that there have been so many bad ones, and good ones have proved too expensive. With transistors having a much lower impedance than tubes it has proved relatively easy to design circuits which do not use an output transformer and so this expensive and bulky component can be dispensed with. It does not matter whether the enthusiast has one, or not, in his equipment — the important thing is that the output of the amplifier works into the correct impedance loudspeaker.

Whilst on the subject of transformers we should explain something about connecting the speaker system to the amplifier. It is often forgotten that a speaker needs *current* to move its speech coil. Now, this current can only get there from the amplifier by flowing through the connecting leads. At 15 watts output, an 8 ohm speaker will take a current of getting on for $1\frac{1}{2}$ amps. So, think about the thickness of the connecting leads. Obviously there comes a limit to the distance that thin wire can be used and when the distance becomes very great one ends up using tram lines! There is, of course, a more sophisticated way of doing this and the professionals use a transformer to step-up the output to around 100 volts, just as electric power is distributed, and then step-down wherever it is needed. The professional sound engineer talks of a “100 volt line” and he has to use a step-down transformer at every speaker point. Volume control of the individual speakers is carried out by a switch selecting a different tap on the transformer at each station.

There is absolutely nothing to prevent the hi-fi enthusiast from wiring a speaker into every room in the house, but special attention has to be given to the power handling capacity of both the speakers and the amplifier and, provided that some thought is given to it, and possibly a little technical help in checking one's figures, the whole thing will prove to be nothing short of superb. If the enthusiast decides to go “100 volt line”,

then he buys the step-up output transformer and mounts it externally to the amplifier, whilst fitting a step-down transformer of the right impedance at each speaker, together with a switch for selecting the maximum power that he wants the speaker to deliver.

Now that the electrical energy has been transformed to a high voltage / low current system the problems of loss of power and mismatch which occur with long thin connecting leads do not apply. Do remember that the transformers have to be very good quality, or else the “fi” will not be very “hi”.

There has always been a great deal of controversy over which is the better — tube, or transistor amplifiers. Listening tests with a wide variety of audiences have shown that provided both comparable tube and transistor amplifiers are well designed and built with good quality components it is almost impossible to distinguish between them. Where the quality of the equipment begins to fall off a bit, then they can be more easily distinguished, the tube amplifier producing the more satisfying results, up to a point, as the quality worsens. It is very difficult to know why this is, but perhaps the microphony of the tubes coupled with the effects produced in the output transformer still give the illusion of sound quality by introducing a timbre of their own into the music, whilst cross-over distortion is rapidly rising in the transistor amplifier.

One last significant factor in sound reproduction is the dynamic range of the installation. The difference between the quietest and the loudest sound that can be produced by a concert orchestra is around 80 dB, or a difference of a hundred million times. The dynamic range of the installation is limited on the one hand by how much power it can deliver (and, not unnaturally, how much pain the enthusiast can stand), and also on the noise level. During quiet passages the noise produced by the equipment may be objectionable if the volume is high and this, in turn, may mean keeping the volume down regardless of the amount of cotton wool the neighbours are using in their ears. There is not much point in buying a superb speaker for an installation that cannot use it, so the enthusiast is advised to study how much noise he is getting at full volume with no input before he goes any further as he may feel that a new amplifier would also be a worthwhile investment.

2.4 Stand By for Stereo

If the enthusiast has stereo equipment he will know that two separate

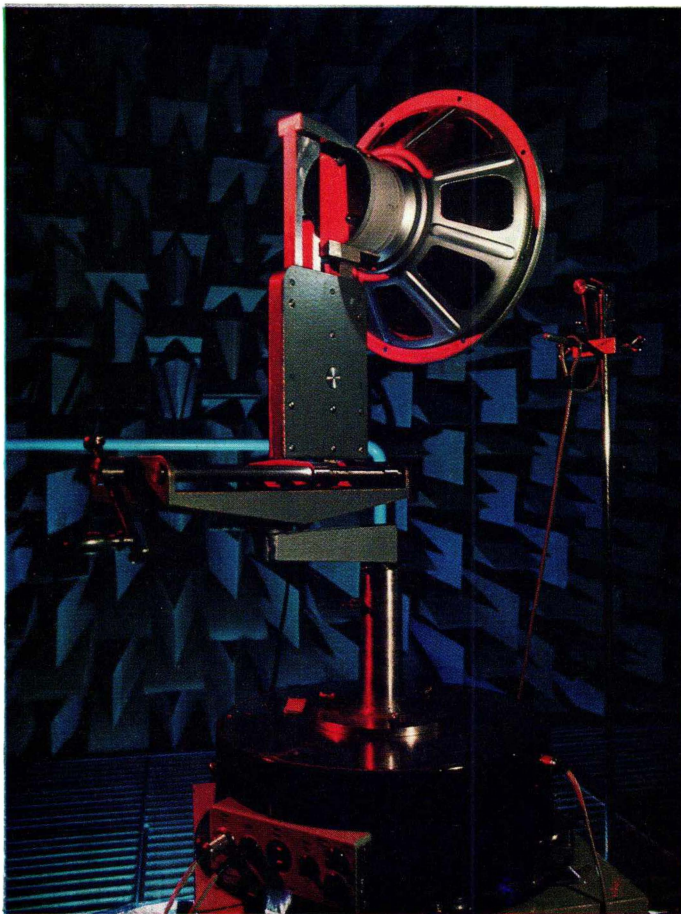

A high fidelity speaker on test in the anechoic room. The speaker is held in a clamp on the test fixture and the microphone positioned 50 cm away. The polyurethane 'wedges' which cover the walls and ceiling absorb all reflections and the room simulates 'free space' conditions. Wedges are also fitted on the floor below the metal grid.

channels of sound reproduction are required. They may be either identical, in which case the listener will hear the reproduced sound in the same way as it was recorded, or, alternatively, the listener may prefer to reserve one side of the sound stage for one group of frequencies, say, the highs, and reproduce the whole of the frequency range on the other side. All this is a matter of personal preference, but it must be emphasized that only when the two channels are identical, and that includes the speakers, will the original sound distribution be reproduced.

One of the greatest problems of stereo reproduction in the home is the positioning of the speakers. More will be said about this later, but with stereo one of the unhappy effects one gets is that of the “hole in the middle”. If the equipment is fitted with a width, or dimension control then this problem is lessened to a great extent. This control is capable of mixing both the left and right channels and when it is fully anti-clockwise the two channels are completely merged, giving dual-mono. Equal signals are then fed to each speaker and the effect is that the sound appears to come from a point midway between the two speakers. As the control is advanced slowly in a clockwise direction the individual character of each channel becomes increasingly felt until, if the speakers are sufficiently far apart, two entirely separate sound sources appear to exist. This is unnatural, of course, and the listener must adjust the width of the sound stage to suit his own particular living room environment, depending on where the speakers have been placed. A lot of experimenting has to be done to make the listening position in the room as large an area as possible, without destroying the stereo effect.

A word of caution here about the balance control. If when sitting in one's favourite listening position, or when using stereo phones, for that matter, the sound *appears* to be properly balanced but the control is not at centre, or a balance meter indicates off-balance, do not be too upset. No one has exactly the same response in both ears and the departure from centre shown by the knob or meter is an indication of the difference between one's left and right ears. If the effect of this bothers you, then forget about stereo and go in for superb mono, or pseudo-stereo where the frequency range is split up to different loudspeakers and it then does not matter where in the room one sits, as the balance between the speaker levels is by no means critical.

Whilst on the subject of stereo we should like to stress the point that all the stereo equipment in the world can never turn a mono source of sound into stereo. For example, a vocalist singing with an orchestra is



In the laboratory outside the anechoic room the recorder plots the frequency response of the speaker under test. The signal fed to the speaker is swept from 20 Hz to 20000 Hz whilst the graph paper is fed through the recorder in synchronism. The amplitude of the response in the microphone controls the pen movement. When the polar response is required, the speaker is rotated in front of the microphone and a polar plotter is used, the test frequency remaining constant.

recorded as a point source of sound and, on playback from tape, or reproduction from disc, appears to stand at a particular *point* on the sound stage. If this were not so a vocalist would appear to have a mouth three metres wide. Of course, some may like it that way. The same applies to solo instruments. What stereo does is to give the music the impression of width, or dimension, adding the effects of the surroundings of the recording studio or concert hall to the singer. This effect can be partially produced when playing a mono recording over a stereo system. It is, of course, dual-mono. But the spread of sound, rather than listening to a point source, creates a different illusion to the listener. One must be careful not to end up with a piano keyboard four metres long, unless one has a passion for pianos. But if the two channels are capable of having their frequency response adjusted individually, that is, if separate tone controls are provided for the left and right channels, then one can arrange one side of the sound stage to reproduce only the high frequencies and a pseudo-stereo effect is produced. Here, a width, or dimension control can be used to good effect where vocalists and solo instruments are concerned, to keep their width in proportion. This applies specially to large sopranos.

Funny things happen with stereo. Just as the listener can artificially adjust the width of his sound stage, so the recording engineer can change the position of a point source of sound by moving a control knob. This device is called a *pan-pot*, which is short for *panoramic potentiometer*, and it is one of the recording engineer's most useful controls. He can move the position of a point source of sound across the sound stage from left to right and so position a vocalist or any solo instrument exactly where they appear best. If the listener gets the impression that a singer is rushing up and down the stage, then the singer is not to blame; it was the recording engineer getting excited.

Many amplifiers and control units are a knob-twiddler's paradise. One control is worthy of mention in connection with stereo; the Left/Right Reversing Switch. It seems beyond the comprehension of most seriously-minded enthusiasts why anyone would want to go to the lengths of fitting a switch to change over the speakers, once they have been connected. Surely, it would be less expensive to change over the plugs on the back of the equipment and then they would be correct for evermore. If, of course, one has a passion for switches it is nice to have it, but the truth is that even recording companies make mistakes and there have been many stereo discs which have the left and right channels reversed in the recording.

2.5 Loudness and Listening

Most radio and television sets are fitted with speakers with a power handling capacity of around three watts maximum, seldom more, whilst transistor portables fit half-watt speakers. How do you reconcile your family to the arrival of two 20 watt speakers? Keep quiet about it! On the basis that the most useful control on a television set is the on/off switch, there appears to be a case for a policy of silence, initially, with a very gradual rise in output over a protracted period of time.

We would suggest that for high fidelity installations there should always be *sufficient* power available, even if the listener has domestic reasons for not using it, and we recommend at least 10 watts for mono. This does not mean that if the listener is going stereo he must have a minimum of 20 watts. The acoustic power produced by any source of sound is shared by both ears, assuming that most listeners have two ears, of course. And the fact that the sound has now spread itself across a panorama, rather than coming from a point source, does not mean that we have to double the amount. We would think that where 10 watts on mono would satisfy a particular case, then 8 watts per channel, that is $8 + 8$ watts of stereo, would suffice. If there are no close neighbours, or the listening room is larger than an average living room, then 15 watts for mono, or $10 + 10$ watts for stereo would be about the figure.

The above figures have been based on what we consider is suitable for comfortable, enjoyable listening, because after all, music is surely for pleasure. It is a personal thing, just how far up the volume should be turned. One may be the type who likes to sit on the front row at a concert, or even in the middle of the orchestra. Alternatively, there are those who like to feel the music, rather than listen to it. This last applies particularly to teenagers, who, the psychologists tell us, derive sensual excitement from its loudness, especially when the beat, or rhythm, is similar to that of the heart. For these latter there is no limit to the number of watts they can stand and special vibrators are being provided to which an addict can be strapped for maximum pleasure.

The dynamic range of the reproduced music depends, as we have already mentioned, on the maximum power that the installation can deliver. This is a one way journey, because there is nothing quieter than silence, so the only way to extend the range is upwards. A 25 watt installation for mono, or a $20 + 20$ watt installation for stereo, will give a superb dynamic range and, provided that the speakers are correctly chosen and

the building can stand the strain, any enthusiast should be more than satisfied with the results. For power ratings much in excess of this used in the home we recommend that all crockery is replaced by plastic utensils and glass mirrors are changed to stainless steel. Doors may be removed from their hinges, but this may affect the properties of the listening room, so be careful. In the extreme case, the most fanatical of power crazy enthusiasts may prefer to treat the listening room as an enclosure and, provided they can obtain a sufficiently large speaker, they can find out exactly what it is like *inside* the enclosure.

It can be shown mathematically that there is an optimum value of power output to suit all 'auditorium' conditions. All kinds of things are taken into account, such as the number of people in the room, the volume of the room and its echo time, absorption of sound by curtains and upholstery, and so on. But we do not feel that this very scientific approach is going to make the slightest difference to how many watts you *want* to have and if you can accommodate a 20 + 20 watt stereo set-up, Good Listening!

2.6 Scrapping the Whole Idea

From what has been said, the enthusiast should now have been able to make up his mind what frequency range he is going to aim at and also what power output and impedance he has available. The choice of the loudspeaker to get the best out of all this lies ahead. Not only will the speaker system have to be chosen carefully, but there comes the question of the shape and size of the enclosure for each speaker. After this irrevocable decision has been made, the enthusiast is faced with building the thing.

One has to be a reasonably careful sort of carpenter. If the services of a machine to accurately cut the panels are available, or the timber supplier will do the cutting, then life is much simpler. Accuracy in *squareness* is important as the enclosure has to be AIR-TIGHT when finished, and unless you are sufficiently keen to make a business-like like job of the whole thing, scrap the idea, and buy a speaker in an enclosure, ready-made. Before doing so, however, read the next Chapter which deals with the speakers themselves. You will then know what to buy, and have a reasonable idea of its expected performance.

3 Loudspeakers for High Fidelity Reproduction

3.1 Speaker Specification

All moving coil loudspeakers operate according to the same general principles. Fig. 1 shows the cross-section of a typical moving-coil loudspeaker in which the amplifier output signal is fed to the speech coil suspended in the gap of a powerful magnet by means of a centring device, or 'spider'

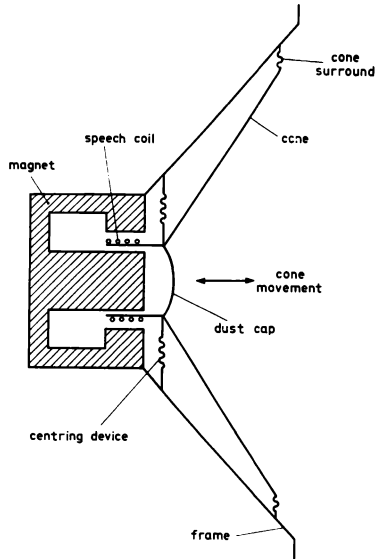

Fig. 1. Showing the construction of a typical moving coil loudspeaker.

The small end of the speaker cone is attached to one end of the coil assembly and the big end is attached to the frame by means of a flexible surround. Since the current flowing in the coil produces a magnetic field at right-angles to the field of the magnet, the attraction and repulsion of these fields causes the coil to move to and fro at the frequency of the electrical signal and sound waves are produced by the motion of the cone.

Since the speaker is an electro-mechanical device, very special attention has to be given to the mechanical requirements. The speaker is the thing

that we hear and any imperfections in its design and use will be immediately apparent. The speaker converts electrical energy into acoustic energy and the ratio of acoustic energy produced to the electrical energy required is the measure of its efficiency. Where high fidelity is concerned, low distortion is much more important than high efficiency, so efficiencies around one or two per cent are commonplace. Much higher efficiency speakers are used, of course, but not for high fidelity reproduction. To avoid having a higher power output from the amplifier than is really necessary, it is essential to choose a speaker that has as high an efficiency as possible within the range of suitable speakers and, to this end, the size of the magnet is the best guide. A powerful magnet, therefore, is one of the main considerations, because the more powerful the magnet, the less the input watts required for the same acoustic output, and the greater will be the transient response of the speaker. The total magnetic flux of the speaker is the best guide to the size of magnet and one would expect this to be around $1000 \mu\text{Wb}$ (100000 Maxwells). The flux density in the gap depends on the particular design of the magnet system, but would typically be 1000 mT (10000 gauss). These values are for a good quality 12-inch speaker.

Loudspeaker design is a compromise, and for producing both good bass and good treble the requirements conflict. A light-weight cone of small diameter is needed for the high frequencies, whilst a large and robust cone is needed for the bass. A glance at Fig. 2, which shows the acoustic power

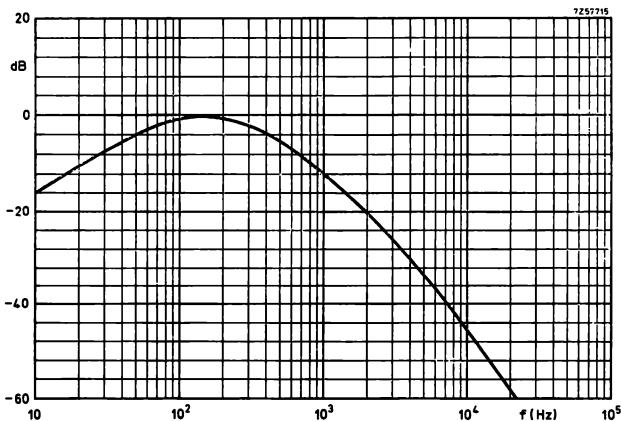

Fig. 2. Showing the relative acoustic power levels arising in speech and music (DIN 45573).

levels arising in speech and music at different frequencies, indicates that to obtain good realistic bass, the speaker has to be capable of handling a fair amount of power, because more power is transmitted at low frequencies than at high. This curve, therefore, shows the relative power levels at which the different frequencies must be reproduced to obtain “high fidelity” as defined by the Standard DIN 45573. A large diameter

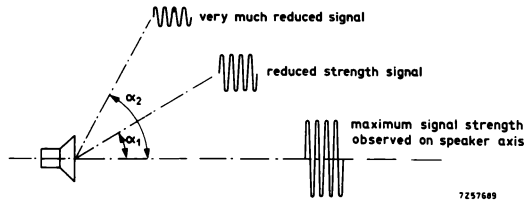

Fig. 3. The strength of the high frequencies decreases at increasing angles to the axis of the speaker.

speaker will normally provide good bass, but at high frequencies the coil is virtually the only part of the speaker that is moving and the acoustic energy is radiated mainly from the apex of the cone. To improve the high frequency output an additional small cone, stiff and lightweight, can be attached to the apex of the main cone. Also the coil can be made very light in weight by winding it, for example, with aluminium wire. A simple speaker can, therefore, reproduce a wide frequency range successfully and there are a number of full-range speakers available in both single and twin cone versions.

The frequency range of the speaker is not the only thing to be considered, however. Low frequencies are always well diffused in the listening area, but, as the frequency is increased, the sound becomes noticeably directional. Fig. 3 shows how the strength of the high frequencies varies at an angle to the axis of the speaker. This beaming effect considerably detracts from realism and the quest for non-directional diffusion accounts for the trend to multi-speaker systems, which will be described later.

Every loudspeaker has a fundamental resonance frequency. The two most important factors in determining what this frequency will be are the mass of the cone and the stiffness of its movement. Because good reproduction cannot be obtained below resonance frequency, the aim is to get the resonance frequency as low as possible. Increasing the mass and reducing the stiffness will lower the resonance frequency; the converse is

also true. In addition, the edge of the cone can also reflect back energy along the cone's surface and colour the reproduction. Many materials have been used to absorb this energy and the latest and most successful, so far, are highly flexible suspensions of butyl-rubber.

A coil has both resistance and inductance. The result is that, as far as the speech coil is concerned, its impedance, and thus the current through the coil will vary with frequency. For the speakers that are detailed in this book, the impedance quoted is the lowest value measured above the resonance frequency. This is the impedance which has to match the recommended load (nominal impedance) of the amplifier. Remember that if the speaker has a lower impedance than that of the amplifier, the amplifier may be damaged and if the speaker impedance is higher there will be a loss of power.

When choosing a speaker it is important to ensure that the power handling capacity of the speaker is adequate. A speaker with a power handling capacity of 10 W can be safely connected to a 10 W amplifier, but there is nothing wrong in connecting it to an amplifier with a lower power output — indeed it is preferable to leave a certain safety margin in this way. If, on the other hand, the speaker is connected to an amplifier with a higher output power than that for which the speaker has been designed, using the amplifier at full power may cause permanent damage to the loudspeaker.

Speakers are tested by applying a 'white' noise signal, of the same spectrum as that shown in Fig. 2, to the speech coil, the voltage level being adjusted so that the power consumption is equal to half the nominal power of the loudspeaker. The speaker is then checked for buzzing, rattling and cone break-up. After the speaker has passed this operational test it is given a continuous load test at full power for 100 hours using a 'white' noise generator.

The frequency response of each of the speakers described in this book is determined by recording through a microphone, 50 cm away along the axis of the speaker, the response to a constant voltage signal of 50 mW (12 inch high quality types 25 mW) as the frequency is swept slowly to 20 000 Hz. The test takes place in an anechoic room and the result is plotted with a pen recorder. 0 dB on the response curves corresponds to 52 dB above the threshold of hearing (2×10^{-4} μ bar). We should emphasize that frequency response curves should only be used as a means of comparison. Never compare curves which are not based on the same system of measurement. Fig. 4 shows a typical response curve.

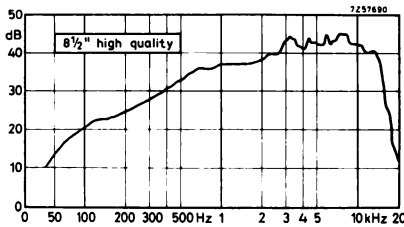

Fig. 4. A typical frequency response curve of a loudspeaker, obtained without baffle in an anechoic room.

Another test carried out is that of the polar response. This measures the directional properties of the speaker which, as we have mentioned before, become noticeable at high frequency. The speaker is placed on a turntable and a constant voltage signal at a particular frequency is applied to the moving coil. The recording microphone is again held 50 cm away and the turntable is rotated. The test is repeated at different frequencies and the results are recorded on polar graph paper. Fig. 5 shows the results obtained from one of our high quality full-range speakers, the 9710/M. The plot at 5000 Hz indicates how directive the sound output becomes as the frequency is increased. The reduced output shown at 90° and 270° in the plot at 500 Hz is due to acoustic “short-circuiting” caused by interference between the waves from the front and the back of the speaker. This latter is prevented when the speaker is mounted on a large board, or in an enclosure.

3.2 Bags of Bass

So far we have discussed speakers from the standpoint of the full-range speaker and, furthermore, we have treated it as being in free space, supported only by a clamp around its magnet. Obviously, speakers have to be housed in some form of enclosure and, although the next Chapter of this book deals with this aspect at some length, it is necessary at this stage to introduce the idea of the enclosure.

The frequency characteristic of a loudspeaker plays a very important part in determining the properties of the speaker. Inspection of the frequency characteristic shows that the speaker reproduces low frequencies worse than high ones. There are two main reasons for this. Firstly, if the frequency of the signal is varied from a high to a low value, the wavelength of the sound produced will increase. As soon as a point is reached

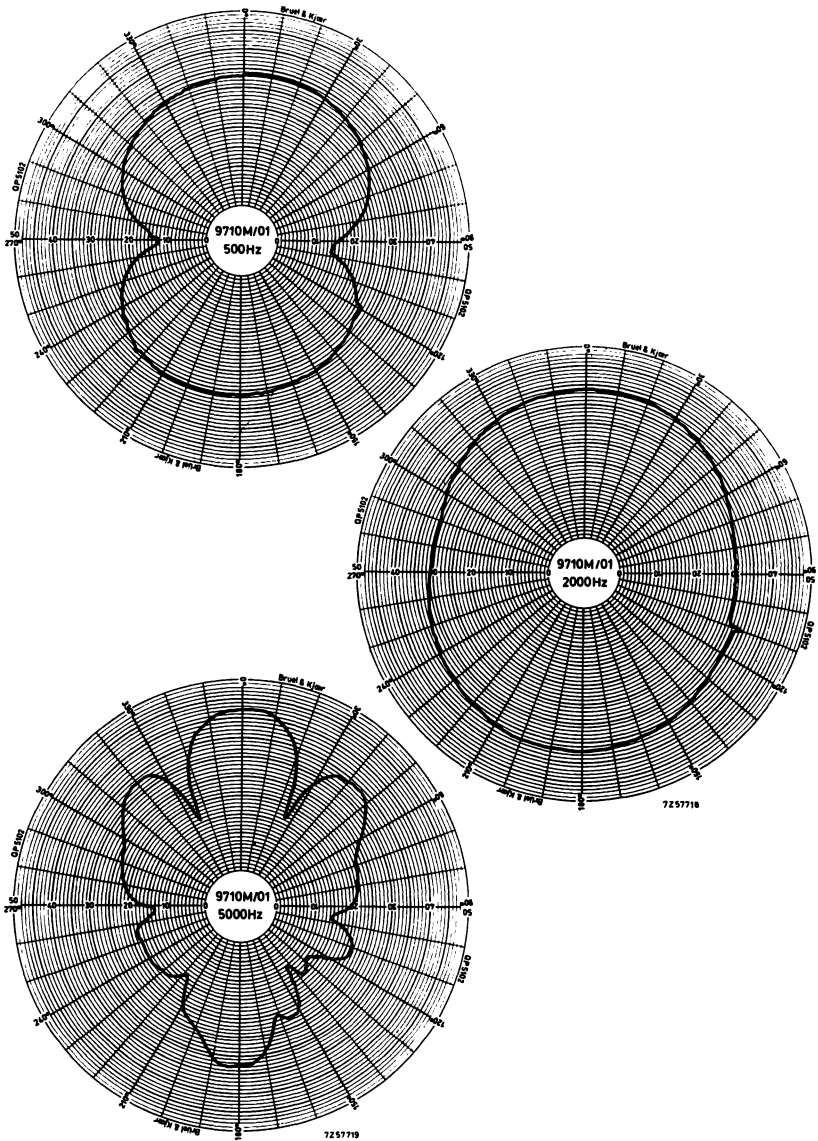

Fig. 5. The polar response curves of a typical high quality full-range speaker at different frequencies. Note the fall in output at 90° and 270° on the 500 Hz curve due to acoustic short-circuiting.

where half the wavelength is equal to the distance from the front of the speaker to the back, the sound pressure will start to decrease by 6 dB per octave as a result of acoustic “short-circuiting”. Secondly, the speaker has the property that the sound pressure falls off even faster below the resonant frequency. The combined effect of both of these is a total attenuation of 18 dB per octave.

The first of the effects mentioned above can be reduced by mounting the speaker on a large board, known as a baffle-board, or baffle, for short. This leads to an immediate improvement in the frequency characteristic, as shown in Fig. 6. Here, f_k is shifted to lower frequencies, thus improving the reproduction of the low tones.

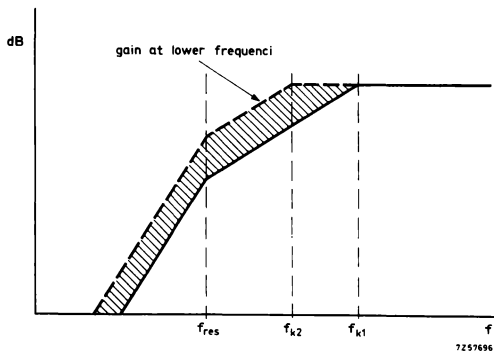

Fig. 6. Showing how a baffle board improves the bass response. (Dotted line — with baffle, solid line — without).

Because such a large baffle would be needed in practice, the solution is to enclose the speaker in a box. The enclosure, in whatever form it takes, has a marked effect upon the performance of the speaker and it is when we come to discuss the bass response that it becomes difficult to treat the speaker in isolation. As we have said, the response of a speaker falls off very rapidly below resonance. An obvious way to improve the reproduction is to try and make the resonance frequency as low as possible. Making the cone suspension more supple, which reduces the stiffness, and increasing the effective mass of the cone are two ways in which the resonance frequency can be reduced. A combination of these measures has led to a series of special loudspeakers with low resonance frequencies, giving good reproduction down to 18 Hz, and also a number of full-range speakers. These speakers give excellent results in a surprisingly small enclosure. One very important point to be borne in mind with these speakers

is that the relatively high power handling capacity quoted for them *only holds good when they are mounted correctly in an enclosure of the right volume*. The air in the enclosure gives additional stiffness which has been taken into account in designing the loudspeaker. If this extra “spring” is missing, or is too small because the enclosure is too big, the speaker could be damaged. Due to the additional stiffness provided by the enclosure the resonance frequency will rise above that for the speaker alone.

Good bass *is* possible with a full-range speaker, down to $\sqrt{2}$ times the resonance frequency, but the size of the enclosure which would be needed to give it makes the whole task prohibitive. For practical reasons the reader must not expect really good bass reproduction where only a simple set-up is employed. Excellent bass will be obtained, however, where a special speaker is used. Such a bass speaker, or *woofer* as it is called, has been specially designed to handle the bass frequencies with low distortion. Its design is not a compromise, like that of the full-range speaker. Since it is devoted primarily to the task of bass note reproduction, the high notes have to have separate treatment. This is dealt with fully under *Multi-Speaker Systems*.

3.3 Simple Set-Ups

To achieve the best results, the enclosure in which the speaker is mounted should be air-tight. This is not the case with most radio receivers. It makes little difference with receivers for amplitude-modulated signals, as the audio frequency range transmitted is very limited. Frequency-modulated broadcasts, which have become much more popular, transmit a much wider audio range and it is, therefore, worthwhile taking far more care to ensure that the best performance from the loudspeaker is obtained.

Many radio receivers, and especially record players, will give much better sound reproduction if the installation is supplemented by an additional speaker in a suitable enclosure; or two for stereo. Since the output power of such installations is generally low and the distortion produced in the output stage is often quite high, a simple loudspeaker system will give adequate results.

Table 1 lists good quality speakers which are available for simple set-ups. The first three types give good results in small enclosures. The remainder are suitable for use in installations where high quality sound is required at higher powers; but they require larger enclosures. The Type 9710/M deserves special mention. When used in enclosures of 30 litres

Table 1. Showing the Range of High Quality Loudspeakers for Simple Installations.

overall ¹⁾ diameter (mm)	total ¹⁾ depth (mm)	power handling capacity (W)	impe- dance (Ω)	total flux (μ Wb) ²⁾	flux density (mT) ³⁾	enclosure volume (l)	hole ¹⁾ diameter in baffle (mm)	frequency range in enclosure (Hz)	type number
5" High Quality									
129	56	6	4 8	294	980	7 max	106	75-20 000	AD 5060/M4 AD 5060/M8
7" High Quality									
166	68	10	5	426	950	15 max	142	60-18 000	AD 7060/M5
8" High Quality									
206	124	6	5	583	1300	≥ 20	180	60-18 000	AD 8050/M5 ⁴⁾
8½" High Quality									
217	114	10	7 800	980	800	≥ 30	193	45-19 000	9710/M 9710/AM
10" High Quality									
261	136	10	7 800	980	800	≥ 30	230	45-18 000	AD 1050/M7 AD 1050/M800
12" High Quality									
315	160	20	7 800	980	800	≥ 40	279	45-19 000	AD 1250/M7 AD 1250/M800 ⁵⁾
315	170	20	7 800	1340	1100	≥ 50	279	45-19 000	AD 1255/M7 AD 1255/M800 ⁵⁾

¹⁾ For full details refer to the mechanical drawings given in the Appendix on page 95.

²⁾ Microwebers $\times 100 =$ Maxwells

³⁾ Milli-teslas $\times 10 =$ Gauss

⁴⁾ High sensitivity

⁵⁾ Very high sensitivity

(1 cu ft) volume, or more, the frequency response approaches that of international high fidelity standards.

3.4 Multi-Speaker Systems

When speech or music is reproduced by a loudspeaker, a mixture of different frequencies is always produced at the same time. The relationship between the force exerted on the moving system of the speaker and the corresponding displacement is not linear. This gives rise to distortion, which is worst when the cone displacement is greatest. If a low tone, which gives rise to a large cone displacement, has to be reproduced together with a high tone, which causes a small displacement, the tops of the waves will be distorted. This effect is very noticeable and gives the sound a disagreeable harshness. It is called intermodulation distortion.

Another effect produced at the same time as intermodulation distortion is *Doppler* distortion. When the cone is set in motion by a low tone, and a high tone is reproduced at the same time, the high tone source is, in fact, being moved by the low tone. This results in the modulation of the high tone by the low tone, which produces unwanted extra frequencies.

When we consider that a speaker for low frequencies should have a high mass, and a speaker for high frequencies should have a low one, it will be clear that the obvious way out of the difficulty is to have separate speakers for high and low frequencies. The frequency spectrum may be divided between two or more loudspeakers, each of which can then have the best characteristics appropriate to its particular frequency range. The electrical division of the frequency spectrum is carried out by means of a filter.

We have already mentioned that the low frequency speaker is known as a *woofer*. A speaker which has been specially designed to reproduce the high frequencies is called a *tweeter*. Two-way systems employing both a woofer and a tweeter are very popular and offer an excellent solution to providing high fidelity reproduction at a reasonable cost. A more advanced system may be employed in which the frequency range is split up into three groups of frequencies. This is known as a three-way system and uses a woofer for the bass reproduction, a tweeter for the treble and a third speaker for the mid-range tones. This third speaker is known as a *squawker*. A three-way system incorporating a woofer, a squawker and a tweeter will give the most perfect coverage to the whole of the audio frequency spectrum and, although it is obviously the most expensive, the results make additional costs more than worthwhile.

When we wish to use two, or three, speakers to cover the whole frequency range we first choose one, or two, points on the frequency spectrum where the frequencies are to be separated. With a two-way system, this point is generally between 750 Hz and 2000 Hz, whilst with a three-way system two points, one between 500 Hz and 750 Hz and the other between 2500 Hz and 5000 Hz are chosen. In a two-way system, the frequencies above a certain point must be attenuated to the woofer; whilst for frequencies below a certain point, they must be attenuated to the tweeter. The three-way system is more complicated, but the same principle applies; as far as the squawker is concerned the frequencies above and below the upper and lower points respectively must be attenuated. A glance at Fig. 7 should make this clear. Not unnaturally, the point

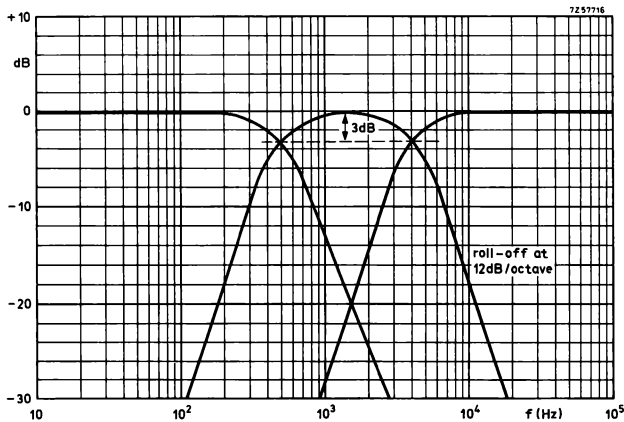

Fig. 7. An idealized frequency response curve of a three-way cross-over filter network. Cross-over frequencies are 500 Hz and 4000 Hz.

at which the frequency characteristics cross one another is called the *cross-over point* and the frequency at which this is arranged to occur is known as the *cross-over frequency*. When determining the position of the cross-over point and the degree of attenuation around it, we must take the frequency characteristics of the speakers into account, since it is important that each loudspeaker will give the correct amount of acoustic energy for the appropriate part of the audio spectrum which it is handling. Where this is a three-way system, the acoustic energy is divided between the three speakers, similarly.

It follows that a filter designed for a given loudspeaker combination will only give first-class results with that particular combination. One cannot use any cross-over filter network with any loudspeaker combination. A selection of possible combinations of speakers for two-way and three-way systems, together with filters, is given on pages 29 to 52. Whilst it is possible to design one's own cross-over networks, the task is slightly more difficult than it at first sight appears. Not only has the cross-over frequency to be decided upon, but the frequency characteristics of both the speakers and the filter have to be taken into account. A much more satisfactory way is to use the speaker manufacturer's recommendations, when it comes to cross-over network design, and to build the appropriate filter which has been recommended by him.

The cross-over filters are not difficult to build. They can be constructed on printed-wiring boards, or on thin plywood, if preferred. The capacitors should be paper dielectric or bipolar electrolytic types. Some of the capacitance values quoted cannot be obtained easily except by combining two or more capacitors in series or parallel. Winding the coils on "C-cores" greatly reduces their size, but where "C-cores" are not readily available, air-cored coils can easily be wound on simple bobbins. Details of cross-over filter components are given in Appendix 1.

For the benefit of enthusiasts who do not necessarily have complete freedom of choice over the impedance of their speakers, it will be useful to know that the values of the inductances used in the cross-over networks are directly proportional to the impedance of the system for which they were designed. The values of the capacitances are inversely proportional to the impedance. Thus, if a filter design is given for, say, an 8 Ω system and the reader has an amplifier which requires 4 Ω speakers, then the inductances can be halved and the capacitances doubled. The converse, going to a 16 Ω installation, is also true.

No discussion on speakers would be complete without mention of our *dome* tweeter, AD0160/T. This speaker is designed specifically for excellent reproduction of the high frequencies. Operating on the same principles as all moving coil speakers, the tweeter has a dome-shaped "cone". In fact, it is not a cone at all, but part of the surface of a sphere. This shape has been decided upon after much research as being the ideal shape to reduce distortion. The ear can tolerate far less distortion at the high frequencies and it is important that there is no interference between the waves leaving the cone. The whole moving structure is extremely light in weight, so that virtually no time is lost in getting it moving in response

to a signal. This results in excellent transient response and relatively high efficiency. Due to the incorporation of a copper ring, which, in conjunction with the speech coil, acts like a short-circuited turn on a transformer, the impedance of the speaker is kept virtually constant over the whole frequency range. The frequency response curves of the dome-tweeter are shown in Fig. 8.

For three-way systems, where a mid-range speaker is required, we recommend the use of our 5 inch woofer, AD5060/W. Working as a squawker, this speaker has ideal performance characteristics over the mid-frequency spectrum. For high powers, two or more speakers are connected in series, parallel, or series-parallel. Table 2 gives the range of special speakers which are available for high-fidelity multi-way systems.

The following list summarizes the 24 high fidelity speaker systems which are described in the next two sections of the book.

Summary of 24 High Fidelity Speaker Systems

system number	woofer		squawker		tweeter		volume (litres)	volume (cu ft)	watts
	(in)	(Ω)	(in)	(Ω)	(in)	(Ω)			
1	5	8	—	—	2	8	3	0.1	10
2	5	4	—	—	2	4	3	0.1	10
3	5	8	—	—	1	8	3	0.1	10
4	5	4	—	—	1	4	3	0.1	10
5	7	8	—	—	5	8	7	0.25	20
6	7	4	—	—	5	4	7	0.25	20
7	7	8	—	—	5	4	7	0.25	20
8	7	4	—	—	5	8	7	0.25	20
9	7	8	—	—	1	8	7	0.25	20
10	7	4	—	—	1	4	7	0.25	20
11	8	8	—	—	5	4	15	0.53	20
12	8	4	—	—	5	8	15	0.53	20
13	8	8	—	—	1	8	15	0.53	20
14	8	4	—	—	1	4	15	0.53	20
15	8	8	5	8	1	8	25	0.88	20
16	8	4	5	4	1	4	25	0.88	20
17	10	8	5	8	1	8	35	1.24	40
18	10	4	5	4	1	4	35	1.24	40
19	10	8	2×5	4	2×1	4	40	1.4	40
20	10	4	2×5	8	2×1	8	40	1.4	40
21	12	8	2×5	4	2×1	4	50	1.77	40
22	12	4	2×5	8	2×1	8	50	1.77	40
23	12	8	4×5	8	4×1	8	80	2.83	40
24	12	4	4×5	4	4×1	4	80	2.83	40

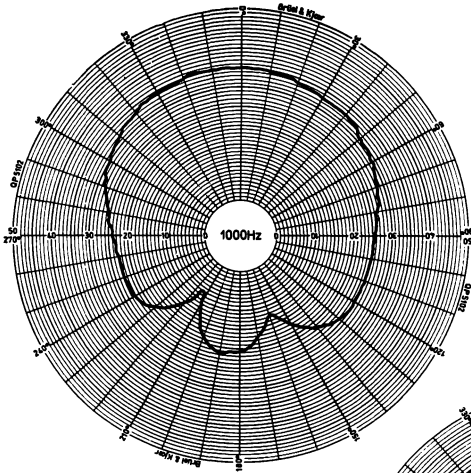

Fig. 8(a). Polar response at 1000 Hz.

Fig. 8(b).
Polar response at 3000 Hz.

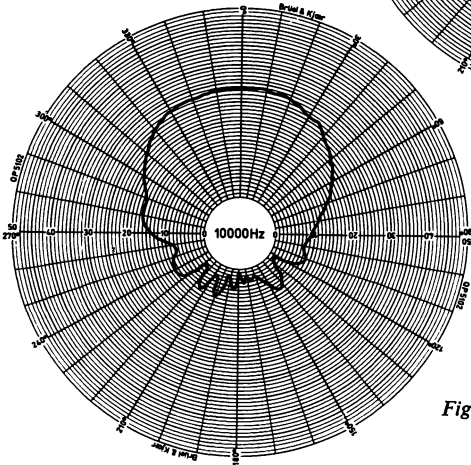
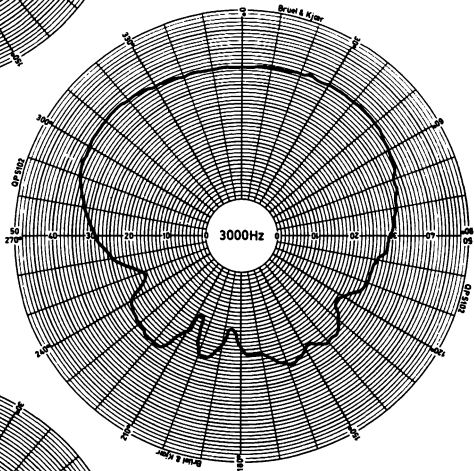

Fig. 8(c). Polar response at 10 000 Hz

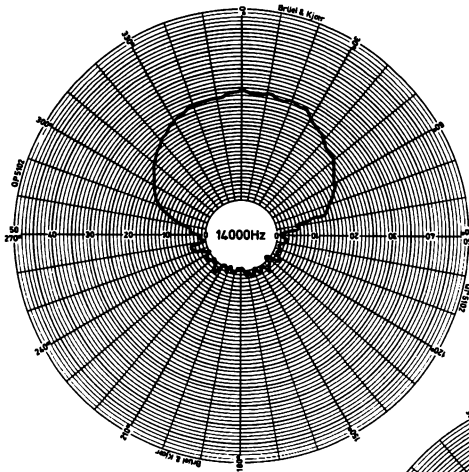

Fig. 8(d). Polar response at 14000 Hz.

Fig. 8(e).
Polar response at 18000 Hz.

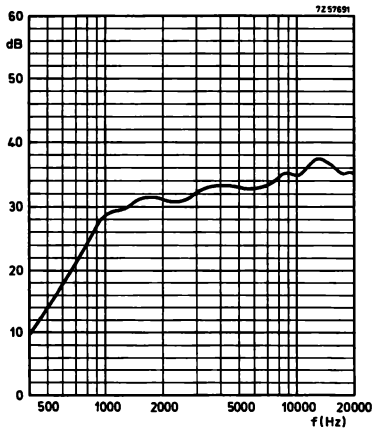
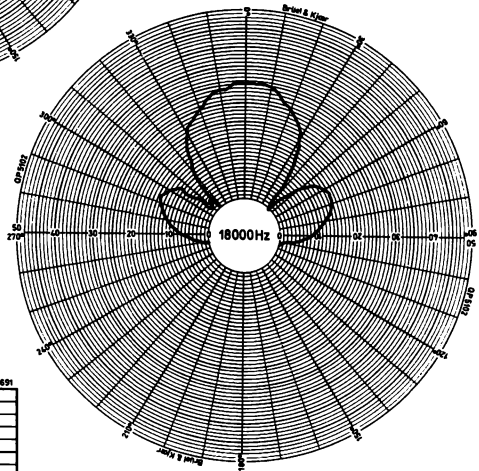

Fig. 8(f).
Frequency response curve of the AD 0160/T.

Fig. 8. Performance characteristics of the one inch tweeter, AD 0160/T.

Table 2. Showing the Range of Loudspeakers for High Fidelity Multi-Way Systems

speaker	type number	overall ¹⁾ diameter (mm)	total ¹⁾ depth (mm)	power handling capacity (W)	impedance (Ω)	resonance frequency (Hz)	total flux (μ Wb)	flux density (mT)	hole ¹⁾ diameter in enclosure (mm)
1" Tweeter	AD 0160/T4 AD 0160/T8	94	27	²⁾	4 8	1000	270	1200	74
2" Tweeter	AD 2070/T4 AD 2070/T8	58	29	³⁾	4 8	800	69	690	52
5" Woofer	AD 5060/W4 AD 5060/W8	129	56	10 ⁴⁾	4 8	50	390	930	106
7" Woofer	AD 7065/W4 AD 7065/W8	166	74	20 ⁴⁾	4 8	28	450	960	142
8" Woofer	AD 8065/W4 AD 8065/W8	206	93	20 ⁴⁾	4 8	28 ⁶⁾	450	900	180
10" Woofer	AD 1055/W4 AD 1055/W8	261	153	40 ⁴⁾	4 ⁵⁾ 8	20	1300	900	230
12" Woofer	AD 1256/W4 AD 1256/W8	315	170	40 ⁴⁾	4 8	19	1210	1070	279

¹⁾ For full details refer to the mechanical drawings given in the Appendix on page 95.

²⁾ Applicable to speaker systems having a maximum power input of 40 W (DIN 45573) when used with the recommended cross-over filter.

³⁾ Applicable to speaker systems having a maximum power input of 20 W (DIN 45573) when used with the recommended cross-over filter.

⁴⁾ In an enclosure of appropriate volume.

⁵⁾ The 4 Ω version of the 10" woofer will become available later in the production programme.

⁶⁾ The *system* resonance frequency is lower with this speaker than when the 7" woofer is used because the larger enclosure required by the 8" woofer results in reduced stiffness and the rise in the enclosure resonance frequency is less.

3.5 Electrical Details of 14 Two-way Systems

SYSTEM 1

IMPEDANCE 8 Ω

5" WOOFER + 2" TWEETER

Woofer — AD 5060/W8
Tweeter — AD 2070/T8

Power Handling Capacity 10 W
Enclosure Volume 3 litres (0.1 cu ft)

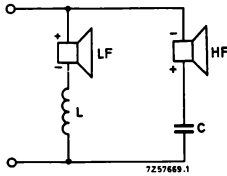

Cross-over Frequency = 2000 Hz.

Cross-over Filter Components:

L = 1 mH,

C = 5 μ F.

Frequency response curve for System 1 measured with speakers mounted in the enclosure.

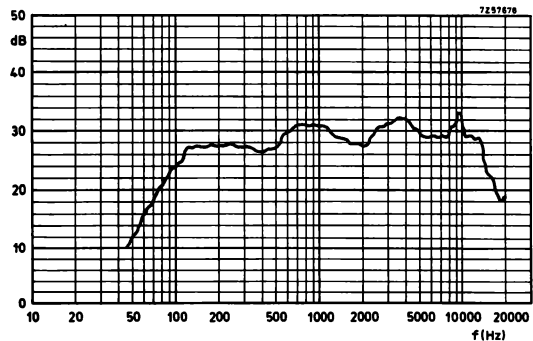

Resonance Frequency = 100 Hz.

5" WOOFER + 2" TWEETER

Woofer — AD 5060/W4
Tweeter — AD 2070/T4

Power Handling Capacity 10 W
Enclosure Volume 3 litres (0.1 cu ft)

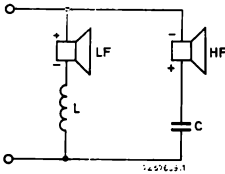

Cross-over Frequency = 2000 Hz.

Cross-over Filter Components:

L = 0.5 mH,

C = 10 μF.

Frequency response curve for System 2 measured with speakers mounted in the enclosure.

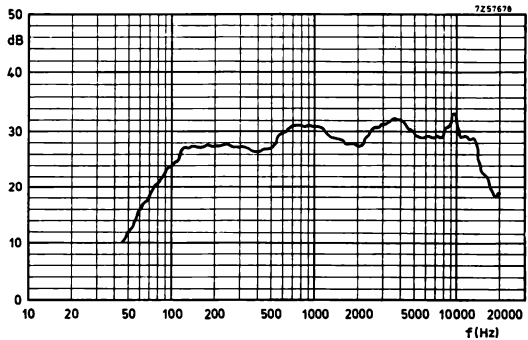

Resonance Frequency = 100 Hz.

5" WOOFER + 1" TWEETER

Woofer — AD 5060/W8
 Tweeter — AD 0160/T8

Power Handling Capacity 10 W
 Enclosure Volume 3 litres (0.1 cu ft)

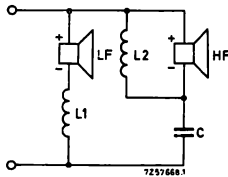

Cross-over Frequency = 1000 Hz.

Cross-over Filter Components:

- $L_1 = 1 \text{ mH}$,
- $L_2 = 0.35 \text{ mH}$,
- $C = 5 \mu\text{F}$.

Frequency response curve for System 3 measured with speakers mounted in the enclosure.

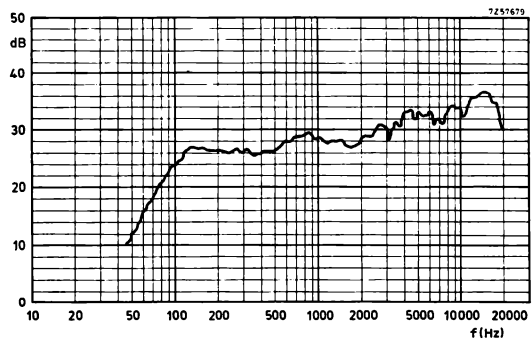

Resonance Frequency = 100 Hz.

5" WOOFER + 1" TWEETER

Woofer — AD 5060/W4
 Tweeter — AD 0160/T4

Power Handling Capacity 10 W
 Enclosure Volume 3 litres (0.1 cu ft)

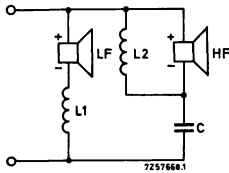

Cross-over Frequency = 1000 Hz.

Cross-over Filter Components:

$L_1 = 0.5 \text{ mH}$,
 $L_2 = 0.175 \text{ mH}$,
 $C = 10 \text{ } \mu\text{F}$.

Frequency response curve for System 4 measured with speakers mounted in the enclosure.

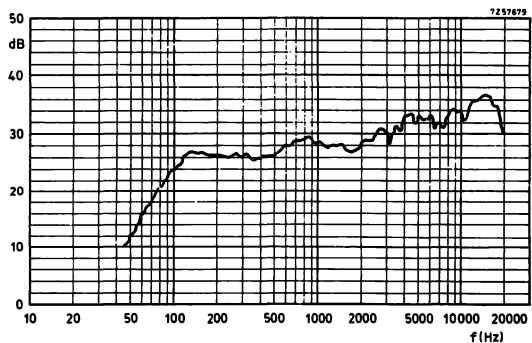

Resonance Frequency = 100 Hz.

7" WOOFER + 5" TWEETER

Woofer — AD 7065/W8
Tweeter — AD 5080/M8

Power Handling Capacity 20 W
Enclosure Volume 7 litres (0.25 cu ft)

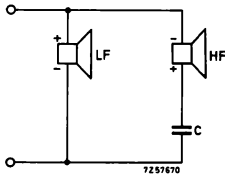

Cross-over Frequency = 1000 Hz.

Cross-over Filter Component:
C = 5 μF.

Frequency response curve
for System 5 measured
with speakers mounted
in the enclosure.

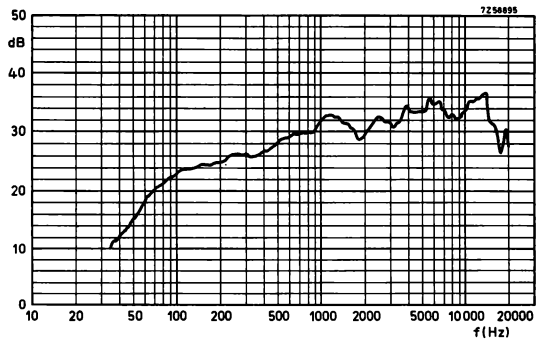

Resonance Frequency = 70 Hz.

7" WOOFER + 5" TWEETER

Woofers — AD 7065/W4
Tweeters — AD 5080/M4

Power Handling Capacity 20 W
Enclosure Volume 7 litres (0.25 cu ft)

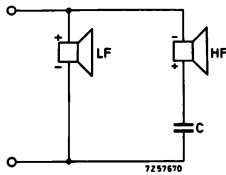

Cross-over Frequency = 1000 Hz.

Cross-over Filter Component:
C = 10 μF.

Frequency response curve for System 6 measured with speakers mounted in the enclosure.

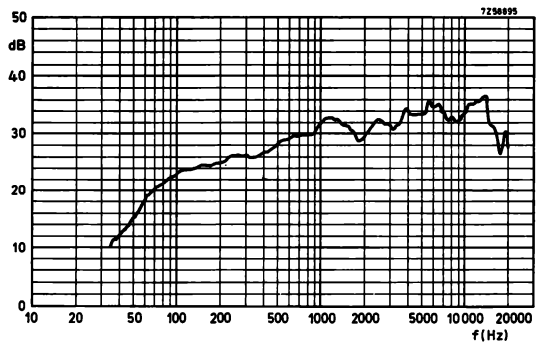

Resonance Frequency = 70 Hz.

7" WOOFER + 5" TWEETER

Woofer — AD 7065/W8
 Tweeter — AD 5080/M4

Power Handling Capacity 20 W
 Enclosure Volume 7 litres (0.25 cu ft)

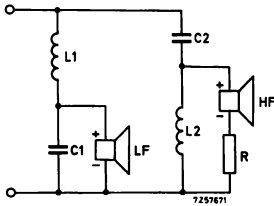

Cross-over Frequency = 850 Hz.

Cross-over Filter Components:

$L_1 = L_2 = 1.2 \text{ mH}$,
 $C_1 = 36 \mu\text{F}$, $C_2 = 12 \mu\text{F}$,
 $R = 3 \Omega \text{ } 2 \text{ W}$.

Frequency response curve for System 7 measured with speakers mounted in the enclosure.

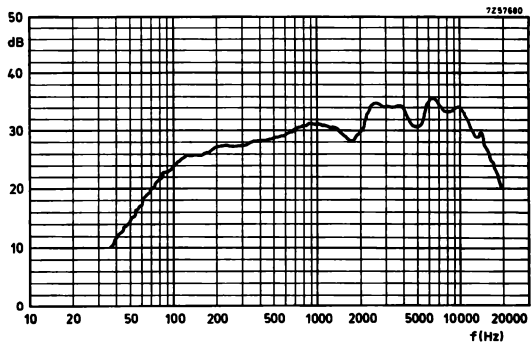

Resonance Frequency = 70 Hz.

7" WOOFER + 5" TWEETER

Woofer — AD 7065/W4
 Tweeter — AD 5080/M8

Power Handling Capacity 20 W
 Enclosure Volume 7 litres (0.25 cu ft)

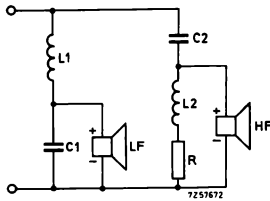

Cross-over Frequency = 850 Hz.

Cross-over Filter Components:

- $L_1 = L_2 = 1.2 \text{ mH}$,
- $C_1 = 72 \mu\text{F}$,
- $C_2 = 24 \mu\text{F}$,
- $R = 10 \Omega \text{ } 5\text{W. Cat.}$

Frequency response curve for System 8 measured with speakers mounted in the enclosure.

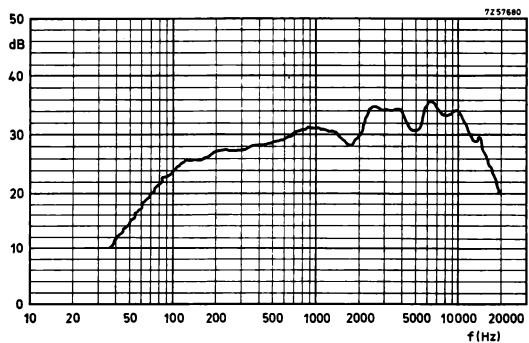

Resonance Frequency = 70 Hz.

7" WOOFER + 1" TWEETER

Woofer — AD 7065/W8
 Tweeter — AD 0160/T8

Power Handling Capacity 20 W
 Enclosure Volume 7 litres (0.25 cu ft)

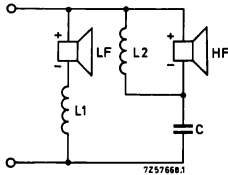

Cross-over Frequency = 1500 Hz.

Cross-over Filter Components:

- $L_1 = 2.1 \text{ mH}$,
- $L_2 = 0.5 \text{ mH}$,
- $C = 8 \text{ }\mu\text{F}$.

Frequency response curve for System 9 measured with speakers mounted in the enclosure.

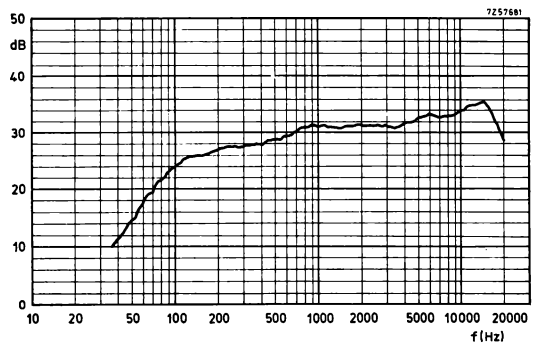

Resonance Frequency = 70 Hz.

7" WOOFER + 1" TWEETER

Woofer — AD 7065/W4
 Tweeter — AD 0160/T4

Power Handling Capacity 20 W
 Enclosure Volume 7 litres (0.25 cu ft)

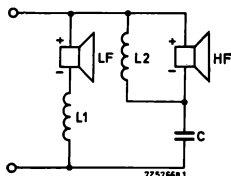

Cross-over Frequency = 1500 Hz.

Cross-over Filter Components:

- $L_1 = 1 \text{ mH}$,
- $L_2 = 0.25 \text{ mH}$,
- $C = 16 \text{ }\mu\text{F}$.

Frequency response curve for System 10 measured with speakers mounted in the enclosure.

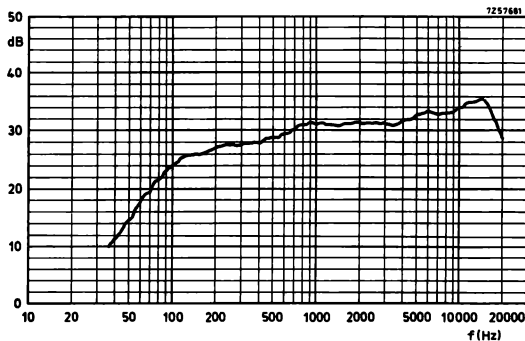

Resonance Frequency = 70 Hz.

8" WOOFER + 5" TWEETER

Woofers — AD 8065/W8
 Tweeters — AD 5780/M4

Power Handling Capacity 20 W
 Enclosure Volume 15 litres (0.53 cu ft)

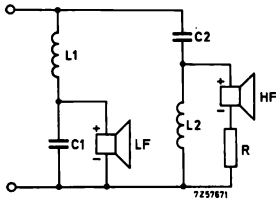

Cross-over Frequency = 850 Hz.

Cross-over Filter Components:

$L_1 = L_2 = 1.2 \text{ mH}$,
 $C_1 = 36 \mu\text{F}$, $C_2 = 12 \mu\text{F}$,
 $R = 3 \Omega \text{ } 2 \text{ W}$.

Frequency response curve for System 11 measured with speakers mounted in the enclosure.

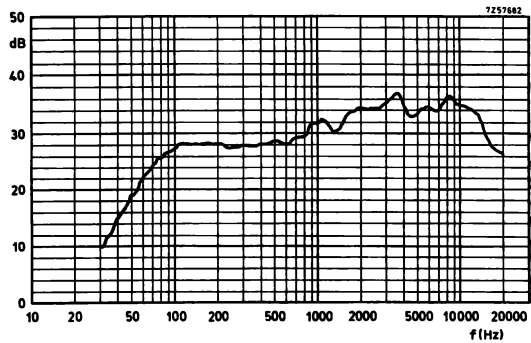

Resonance Frequency = 56 Hz.

8" WOOFER + 5" TWEETER

Woofer — AD 8065/W4
Tweeter — AD 5780/M8

Power Handling Capacity 20 W
Enclosure Volume 15 litres (0.53 cu ft)

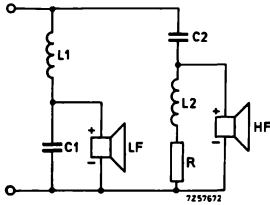

Cross-over Frequency = 850 Hz.

Cross-over Filter Components:

- $L_1 = L_2 = 1.2 \text{ mH}$,
- $C_1 = 72 \mu\text{F}$,
- $C_2 = 24 \mu\text{F}$,
- $R = 10 \Omega \text{ } 5 \text{ W}$.

Frequency response curve for System 12 measured with speakers mounted in the enclosure.

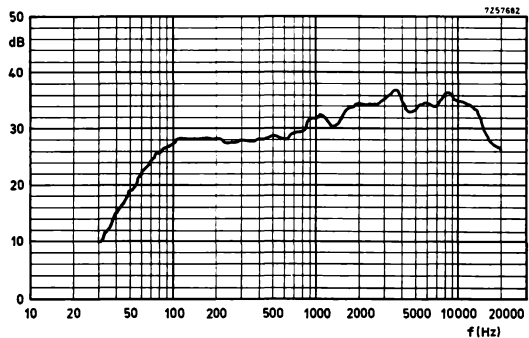

Resonance Frequency = 56 Hz.

8" WOOFER + 1" TWEETER

Woofer — AD 8065/W8
 Tweeter — AD 0160/T8

Power Handling Capacity 20 W
 Enclosure Volume 15 litres (0.53 cu ft)

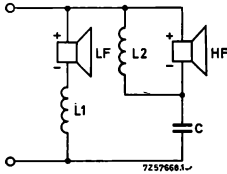

Cross-over Frequency = 1500 Hz.

Cross-over Filter Components:

- $L_1 = 2.1 \text{ mH}$,
- $L_2 = 0.5 \text{ mH}$,
- $C = 8 \text{ }\mu\text{F}$.

Frequency response curve for System 13 measured with speakers mounted in the enclosure.

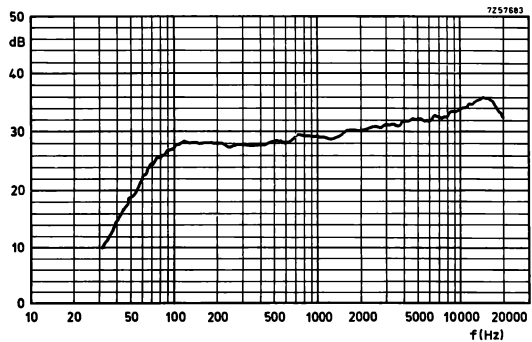

Resonance Frequency = 56 Hz.

8" WOOFER + 1" TWEETER

Woofers — AD 8065/W4
 Tweeter — AD 0160/T4

Power Handling Capacity 20 W
 Enclosure Volume 15 litres (0.53 cu ft)

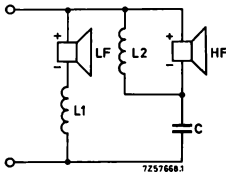

Cross-over Frequency = 1500 Hz.

Cross-over Filter Components:

- $L_1 = 1 \text{ mH}$,
- $L_2 = 0.25 \text{ mH}$,
- $C = 16 \text{ } \mu\text{F}$.

Frequency response curve for System 14 measured with speakers mounted in the enclosure.

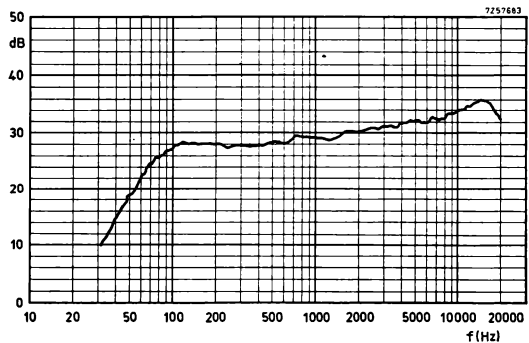

Resonance Frequency = 56 Hz.

3.6 Electrical Details of 10 Three-way Systems

SYSTEM 15

IMPEDANCE 8 Ω

8" WOOFER + 5" SQUAWKER + 1" TWEETER

Woofer — AD 8065/W8
 Squawker — AD 5060/W8
 Tweeter — AD 0160/T8

Power Handling Capacity 20 W
 Enclosure Volume 25 litres (0.88 cu ft)

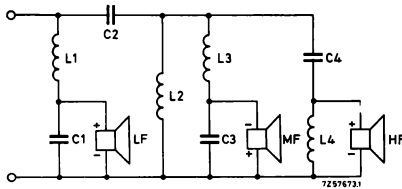

Cross-over Frequencies
700 Hz and 3000 Hz.

Cross-over Filter Components:

$L_1 = 3.0 \text{ mH}$, $L_2 = 1.2 \text{ mH}$,
 $L_3 = 0.5 \text{ mH}$, $L_4 = 0.35 \text{ mH}$,
 $C_1 = 36 \mu\text{F}$, $C_2 = 12 \mu\text{F}$,
 $C_3 = 8 \mu\text{F}$, $C_4 = 3.3 \mu\text{F}$.

Frequency response curve for System 15 measured with speakers mounted in the enclosure.

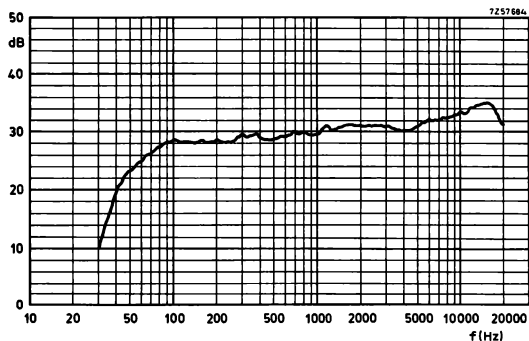

Resonance Frequency = 49 Hz.

8" WOOFER + 5" SQUAWKER + 1" TWEETER

Woofer — AD 8065/W4
 Squawker — AD 5060/W4
 Tweeter — AD 0160/T4

Power Handling Capacity 20 W
 Enclosure Volume 25 litres (0.88 cu ft)

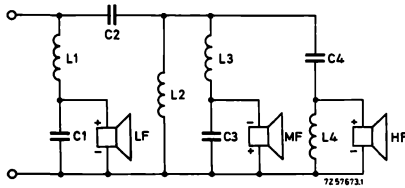

Cross-over Frequencies
 700 Hz and 3000 Hz.

Cross-over Filter Components:

$L_1 = 1.5 \text{ mH}$, $L_2 = 0.6 \text{ mH}$,
 $L_3 = 0.25 \text{ mH}$, $L_4 = 0.175 \text{ mH}$,
 $C_1 = 72 \mu\text{F}$, $C_2 = 24 \mu\text{F}$,
 $C_3 = 16 \mu\text{F}$, $C_4 = 6.6 \mu\text{F}$.

Frequency response curve
 for System 16 measured
 with speakers mounted in
 the enclosure.

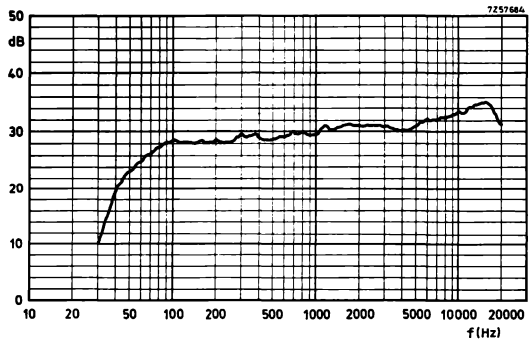

Resonance Frequency = 49 Hz.

10" WOOFER + 5" SQUAWKER + 1" TWEETER

- Woofers — AD 1055/W8
- Squawker — AD 5060/W8
- Tweeter — AD 0160/T8

Power Handling Capacity 40 W
 Enclosure Volume 35 litres (1.24 cu ft)

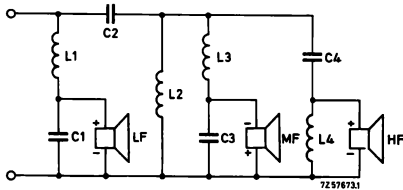

Cross-over Frequencies
 700 Hz and 3000 Hz

Cross-over Filter Components:

- $L_1 = 6.4 \text{ mH}$, $L_2 = 1.2 \text{ mH}$,
- $L_3 = 0.5 \text{ mH}$, $L_4 = 0.35 \text{ mH}$,
- $C_1 = 12 \mu\text{F}$, $C_2 = 12 \mu\text{F}$,
- $C_3 = 8 \mu\text{F}$, $C_4 = 3.3 \mu\text{F}$.

Frequency response curve for System 17 measured with speakers mounted in the enclosure.

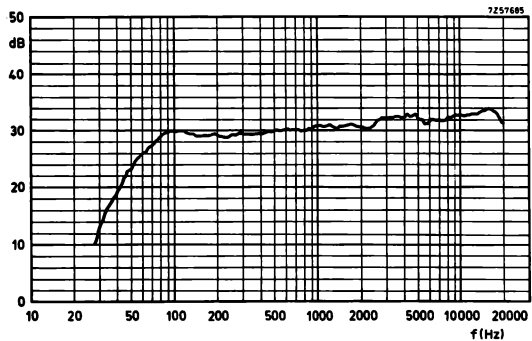

Resonance Frequency = 44 Hz.

10" WOOFER + 5" SQUAWKER + 1" TWEETER

Woofer — AD 1055/W4
 Squawker — AD 5060/W4
 Tweeter — AD 0160/T4

Power Handling Capacity 40 W
 Enclosure Volume 35 litres (1.24 cu ft)

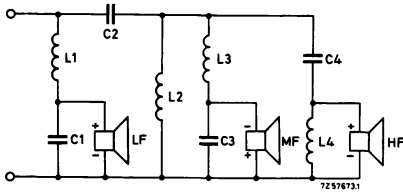

Cross-over Frequencies
 700 Hz and 3000 Hz.

Cross-over Filter Components:

$L_1 = 3.2 \text{ mH}$, $L_2 = 0.6 \text{ mH}$,
 $L_3 = 0.25 \text{ mH}$, $L_4 = 0.175 \text{ mH}$,
 $C_1 = 24 \mu\text{F}$, $C_2 = 24 \mu\text{F}$,
 $C_3 = 16 \mu\text{F}$, $C_4 = 6.6 \mu\text{F}$.

Frequency response curve
 for System 18 measured
 with speakers mount-
 ed in the enclosure.

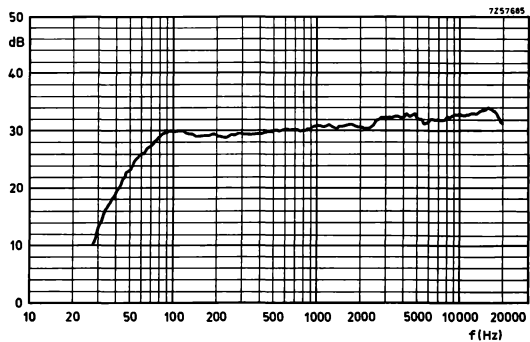

Resonance Frequency = 44 Hz.

10" WOOFER + 2×5" SQUAWKERS + 2×1" TWEETERS

- Woofers — AD 1055/W8
- Squawker — 2×AD 5060/W4
- Tweeter — 2×AD 0160/T4

Power Handling Capacity 40 W
 Enclosure Volume 40 litres (1.4 cu ft)

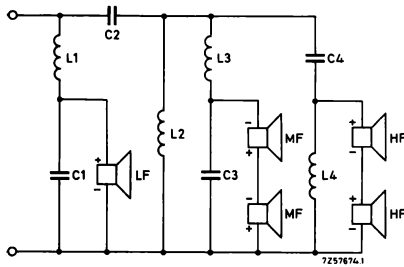

Cross-over Frequencies
 700 Hz and 3000 Hz.

Cross-over Filter Network as for System 17 showing the squawkers in series and the tweeters in series.

Frequency response curve for System 19 measured with speakers mounted in the enclosure.

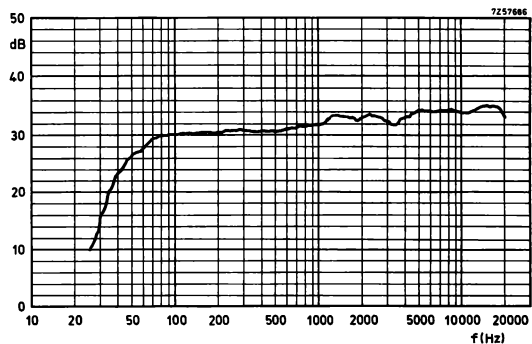

Resonance Frequency = 41 Hz.

10" WOOFER + 2×5" SQUAWKERS + 2×1" TWEETERS

Woofer — AD 1055/W4
 Squawker — 2×AD 5060/W8
 Tweeter — 2×AD 0160/T8

Power Handling Capacity 40 W
 Enclosure Volume 40 litres (1.4 cu ft)

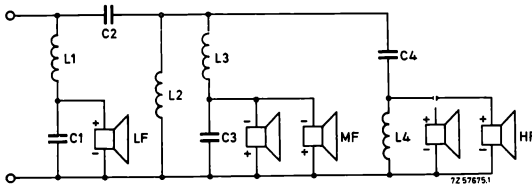

Cross-over Frequencies
 700 Hz and 3000 Hz.

Cross-over Filter Network as for System 18 showing the
 squawkers in parallel and the tweeters in parallel.

Frequency response curve
 for System 20 measured with
 speakers mounted in the enclosure.

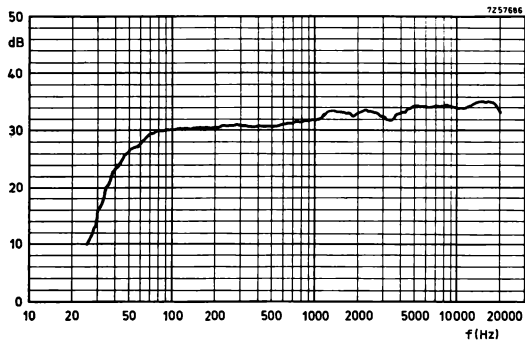

Resonance Frequency = 41 Hz.

12" WOOFER + 2×5" SQUAWKERS + 2×1" TWEETERS

Woofer — AD 1256/W8

Power Handling Capacity 40 W

Squawker — 2×AD 5060/W4

Enclosure Volume 50 litres (1.77 cu ft)

Tweeter — 2×AD 0160/T4

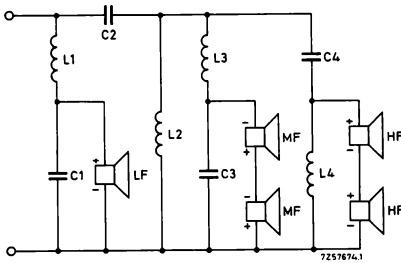

Cross-over Frequencies
700 Hz and 3000 Hz.

Cross-over Filter Network as for System 17 showing the squawkers in series and the tweeters in series.

Frequency response curve for System 21 measured with speakers mounted in the enclosure.

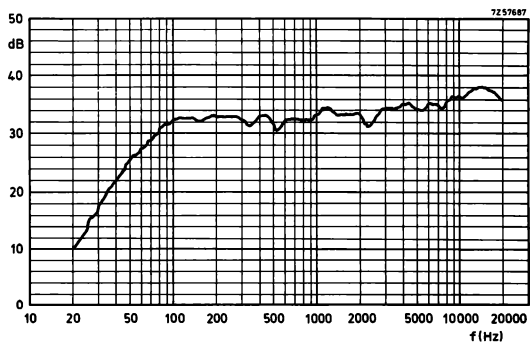

Resonance Frequency = 55 Hz.

12" WOOFER + 2x5" SQUAWKERS + 2x1" TWEETERS

Woofers — AD 1256/W4

Power Handling Capacity 40 W

Squawker — 2x AD 5060/W8

Enclosure Volume 50 litres (1.77 cu ft)

Tweeter — 2x AD 0160/T8

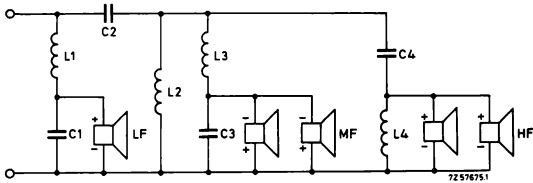

Cross-over Frequencies
700 Hz and 3000 Hz.

Cross-over Filter Network as for System 18 showing the squawkers in parallel and the tweeters in parallel.

Frequency response curve for System 22 measured with speakers mounted in the enclosure.

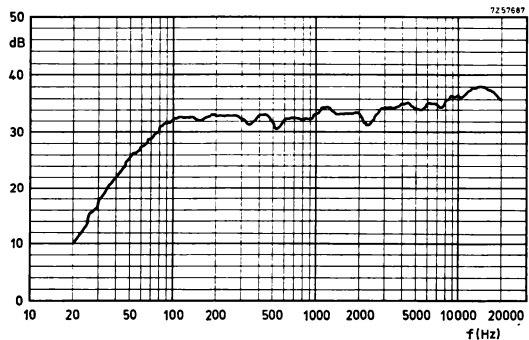

Resonance Frequency = 55 Hz.

12" WOOFER + 4×5" SQUAWKERS + 4×1" TWEETERS

Woofers — AD 1256/W8

Power Handling Capacity 40 W

Squawker — 4×AD 5060/W8

Enclosure Volume 80 litres (2.83 cu ft)

Tweeter — 4×AD 0160/T8

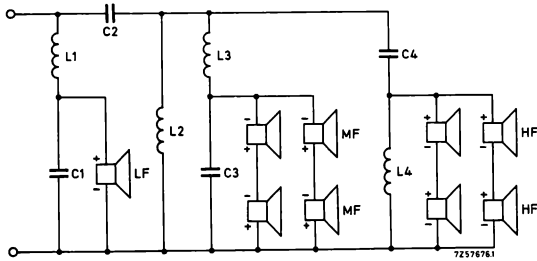

Cross-over Frequencies
700 Hz and 3000 Hz.

Cross-over Filter Network as for System 17 showing the squawkers in series/parallel and the tweeters in series/parallel.

Frequency response curve for System 23 measured with speakers mounted in the enclosure.

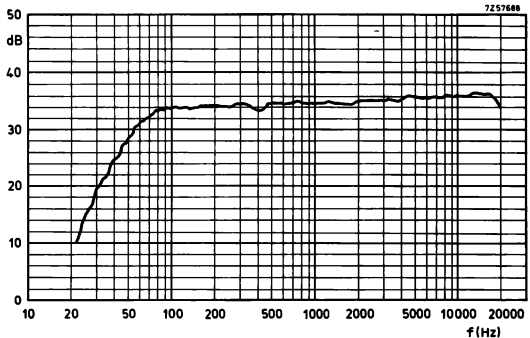

Resonance Frequency = 45 Hz.

12" WOOFER + 4×5" SQUAWKERS + 4×1" TWEETERS

Woofers — AD 1256/W4

Power Handling Capacity 40 W

Squawker — 4×AD 5060/W4

Enclosure Volume 80 litres (2.83 cu ft)

Tweeter — 4×AD 0160/T4

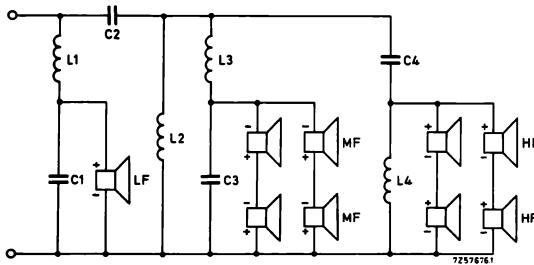

Cross-over Frequencies
700 Hz and 3000 Hz.

Cross-over Filter Network as for System 18 showing the squawkers in series/parallel and the tweeters in series/parallel.

Frequency response curve for System 24 measured with speakers mounted in the enclosure.

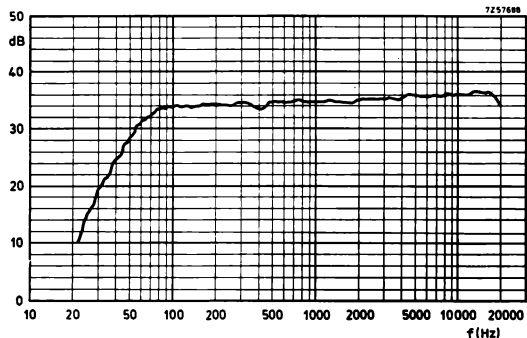

Resonance Frequency = 45 Hz.

4 Enclosures for High Fidelity Systems

4.1 Baffled

Where simplicity of construction is concerned, the baffle is the easiest way of separating the output from the front and back of the cone. There is still some cancellation, as we have discussed in Section 3.2, but at a frequency which depends on the shortest dimension of the baffle board, which should be half the wavelength of the lowest note to be produced. The wavelength of a 40 Hz tone is 8.5 metres approximately, (28 ft). Half a wavelength is, therefore, 4.25 metres (14 ft), so a baffle approximately 4.25 metres square would be required. In practice, the size can be reduced due to the area of the baffle being effectively increased by the floor area on which it is standing, or the area of the adjacent walls to which it is attached. Taken to its logical conclusion, the walls of a room can be used very effectively, the speaker mounted in the wall. If this is attempted, the reader should make sure that where *a hole is cut right through the wall* the back of the speaker is protected in some way, such as by a large open-backed cupboard. Failure to do this will inevitably result in the destruction of the speaker as soon as someone shuts one of the room doors, since the air pressure change in the room will blow the speaker cone out.

4.2 Vented Enclosures

There are many excellent books on the subject of vented enclosures; it is not intended here to do more than briefly mention the principles involved. When a vent is cut in the wall of a sealed enclosure, the enclosure behaves as a resonating system due to the behaviour of the air near the vent. The frequency depends on the volume of the air and the dimensions of the vent. This is the principle of the “reflex” enclosures which are in very common use. The resonance frequency has to be matched to that of the speaker, and thus the correct acoustic loading is applied to the cone — this is what is required for good clean bass. The bass reproduction qualities of the reflex enclosure have done much to enhance its reputation and bass-reflex enclosures will be found all over the world. Tuning the vent is an interesting and exciting business, but very few home constructors will have the necessary equipment to perform this task. Unfortuna-

tely, the size of a bass-reflex enclosure prohibits its use in normal domestic surroundings, especially if good reproduction of frequencies of the order of 40 Hz is being considered.

4.3 Sealed Enclosures

Sealed enclosures are the trend these days. Their relatively small size and amazingly good frequency response has won over the most doubting of connoisseurs. Since the sealed enclosure prevents interaction between the sound waves produced on both sides of the speaker, the system behaves as though the speaker was mounted on an infinitely large baffle board and, for this reason, the sealed enclosure is also known as the “infinite baffle”.

Good bass response can only be obtained from conventional speakers by means of complex or very bulky enclosures. Our approach is to use specially designed speakers, but in simple housings which the reader can easily construct. The shape of the enclosure is left to the discretion of the constructor, as long as certain rules are followed.

The first rule is that **THE RECOMMENDED VOLUME OF THE ENCLOSURE SHALL BE USED.**

It is possible to vary the *relative* dimensions, as long as the box is not made too shallow. As a working rule, **THE DEPTH OF THE ENCLOSURE SHALL BE AT LEAST 1½ TIMES THE DEPTH REQUIRED FOR THE LOUDSPEAKER.**

The third rule, which applies to multi-way systems, is that **ONLY OUR HIGH FIDELITY RANGE OF SPEAKERS SHALL BE USED.** The reasons are that the high quality range of loudspeakers require bigger housings and that only our high fidelity range will produce the results which have been shown in the frequency response curves given on pages 29 to 52.

The reader who wants to build a simple installation, such as one described in Section 3.3 should first refer to Table 1 on page 21. There he will find the required volume for the enclosure appropriate to the speaker he has chosen. The depth of the speaker is then obtained from the Appendix at the end of the book and, by adding half as much again, he will arrive at the minimum depth of the enclosure. He now multiplies by the largest diameter across the frame and divides the result into the volume given in Table 1. The final answer will be the *maximum* height of the enclosure. All these dimensions are, of course, *the internal dimensions*, and the thickness of the material with which the enclosure is made still has to be taken into account before it can be cut.

As a guide to the order of dimensions which the reader should end up with, Table 3 shows a few calculations which have been made. It is stressed that the reader may make the enclosure deeper than the minimum shown in the Table, but NOT LESS or the frequency response could suffer.

Table 3. Showing Limits of Enclosure Dimensions for Simple Installations.

speaker type	min. depth (mm)	min. width (mm)	max. height (mm)	volume (l)	volume (cu ft)
AD5060/M	85	125	650	7	0.25
AD7060/M	105	160	900	15	0.53
AD8050/M	185	195	560	20	0.70
9710/M	170	220	800	30	1.06
AD1050/M	205	265	560	30	1.06
AD1250/M	240	315	520	40	1.41
AD1255/M	255	315	620	50	1.77

The procedure for calculating the dimensions of enclosures for multi-way systems is exactly the same as that which has been described for simple set-ups. Table 4 shows the limits of dimensions for multi-way systems, where cross-reference is made to the appropriate system number given on pages 29 to 52. Problems arise, however, with multi-way systems because of the necessity to keep the tweeters and squawkers acoustically isolated from the woofer. The volume quoted for an enclosure is the *woofer* volume, that is to say, it is the volume of air whose stiffness is just right for that particular woofer. Where other speakers are included in the same enclosure care has to be taken to keep the volume of these speakers, plus any isolating boxes, from reducing the volume of air available to the woofer. For this reason the dimensions of the enclosure may indicate that the volume is greater than at first sight appears necessary. For example, the dimensions for the 80-litre enclosure, described later in the book, give a volume of 85 liters. But only 80 litres of that is available to the woofer. Where the 1 in dome-tweeter is used, no acoustic isolation is required; it is a sealed unit. For other types of tweeter and mid-range units, the best way of isolating them is to cover the back with a plastic 'pot'. For the home-constructor building a small wooden box over the back of the speaker is usually the cheapest solution. This box must be made just as air-tight as the main enclosure.

Table 4. Showing Limits of Dimensions of Enclosures for Multi-Way Systems

system no.	page no.	largest speaker	min. depth (mm)	min. width (mm)	max. height (mm)	volume (l)	volume (cu ft)
1	29	AD5060/W	86	125	280	3	0.1
2	30						
3	31						
4	32						
5	33	AD7065/W	112	156	400	7	0.25
6	34						
7	35						
8	36						
9	37						
10	38						
11	39	AD8065/W	132	195	585	15	0.53
12	40						
13	41						
14	42						
15	43	AD8065/W	132	195	975	25	0.88
16	44						
17	45	AD1055/W	220 *	262	610	35	1.24
18	46						
19	47	AD1055/W	220 *	262	700	40	1.41
20	48						
21	49	AD1256/W	225 *	315	700	50	1.77
22	50						
23	51	AD1256/W	225 *	315	1130	80	2.83
24	52						

* It is possible to reduce the minimum depth of enclosures using the 10" and 12" woofers to 136 mm and 160 mm respectively, i.e., the minimum depth which will accommodate the speakers. These speakers have Ticonal magnet systems, which are longer than the Ferroxdure magnets employed on the smaller woofers, and to avoid very deep enclosures the "one-and-a-half-times" rule *may* be applied in these cases to the cone only. But this would result in an enclosure having less depth than the speaker and, since no one appears to want an enclosure with the speaker magnet sticking out of the back of it, the minimum depth of the enclosure must be that which will accommodate the speaker.

In order to make the home constructor's task easier we have given suggestions for baffle board layouts for the complete range of 24 speaker systems. In addition, the sizes of all the materials required to build the enclosures are given. This range of enclosures has an *aspect ratio* of 5 : 3, that is, the ratio of height/width. Not all readers will necessarily wish to have this particular shape so, in order to show the reader how the dimensions are calculated, the next section of the book will be devoted to the step-by-step construction of a typical enclosure for a two-way system. If the reader prefers to design his own enclosure he can follow the same procedure, but with dimensions better suited to his needs.

In general, with a system using three speakers the woofer should be at the bottom with the tweeter and squawker above. These latter should be at different levels. Where an isolating box is built inside the enclosure it will help to stiffen the baffle board if one of its sides is on the centre line of the woofer. When the system uses five or more speakers it becomes very difficult to give the reader rules that are simple to follow. Closely-spaced speakers react sharply with one another, but if the stacking is vertical it is usually not objectionable; only the polar diagram in the vertical plane is noticeably affected, and this will not be obvious unless the listener has one ear much higher than the other. Close horizontal spacing should be avoided. Also, the tweeters should not be on the same level as the squawkers because of interaction at cross-over frequency. A glance at the suggested baffle board layouts will make this clear.

The 80-litre enclosure shown on page 87 is of particular interest. Here the problem is very complex, since the aspect ratio has to be maintained despite the inclusion of nine speakers. The squawkers have been arranged in a vertical column, but placed lower than the woofer, so that any losses will be mid-range, whilst maintaining good clean bass. Since the ear has maximum sensitivity in the mid-frequency region, loss of output due to masking effects can be better tolerated. The tweeters are so far apart that no interaction between them is possible in either the horizontal or vertical plane.

It appears to be conventional that the woofer is always placed at the bottom of the enclosure, with tweeters and squawkers at the top. The layout of the 80-litre baffle contradicts this. To put the reader at his ease, we should point out that there is no great scientific reason for having the woofer on the floor. The answer is that, in most cases if it *was* at the top, the enclosure would fall over because woofers are very heavy, but in the 80-litre enclosure there is a lot of weight at the bottom also, to balance it.

Laying an enclosure on its side will make little difference to the sound where systems use only one full-range speaker, or one speaker to cover a particular part of the frequency range. Where two or more speakers reproducing the same sound are employed, such as with two tweeters or squawkers, the interaction of the sound waves is often different in the horizontal and vertical planes and the listener may then find a distinct change in the reproduction when such an enclosure is laid on its side.

The rigidity of enclosures is very important. Vibration of the panels will produce unpleasant effects. We recommend that a 3-litre enclosure be built with 10 mm thick walls, whilst a 7-litre enclosure should be 15 mm thick. For larger enclosures below 35 litres at least 20 mm thick materials should be used, with 25 mm from that volume upwards.

To prevent internal reflections within the enclosure and the setting-up of standing waves, the enclosure should be lined — sides, top and bottom, and back — with a suitable damping material at least 25 mm (1 in) thick. Acetate fibre is best, followed by glass fibre (use rubber gloves). Most foam plastic materials, such as polyester and polyurethane are too 'solid'.

The actual method of constructing the speaker enclosure is left to the discretion of the reader. As an example we are giving step-by-step constructional details for System 9, which is summarized on page 37. This installation uses the 7 inch woofer and the 1 inch tweeter. It has a power handling capacity of 20 W, and uses a simple cross-over filter which can be easily assembled.

Building an Enclosure — in Pictures

The following series of pictures were taken during the construction of the 7-litre enclosure for System 9. The sizes of the timber were first calculated by the method described, then the timber was cut and the holes in the baffle board were made. Plywood was used for the panels, with deal for the battens and the grille cloth frame. The material used for the grille cloth was one with a suitable open weave, so that the sound would not be affected.

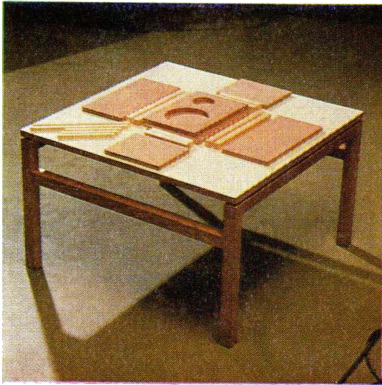

All parts cut to size and laid out ready for assembly. The pieces for the grille cloth frame can be seen at the edge of the table.

Positioning the battens. The back must be flush with the top and side panels. Glue and screw the battens in position.

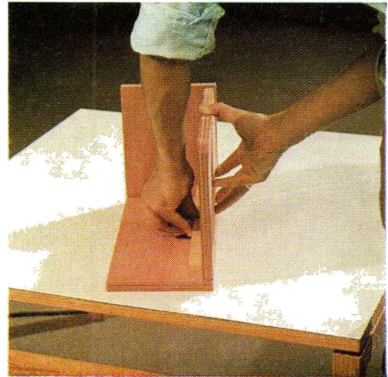

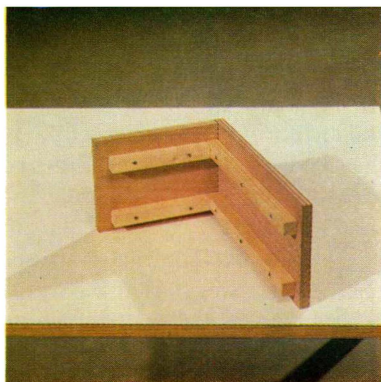

The top with one side panel standing against it. The positions of the screws can be clearly seen.

The tweeter has been fitted after staining the baffle black. The woofer is then screwed into position. Washers are placed under the screw heads.

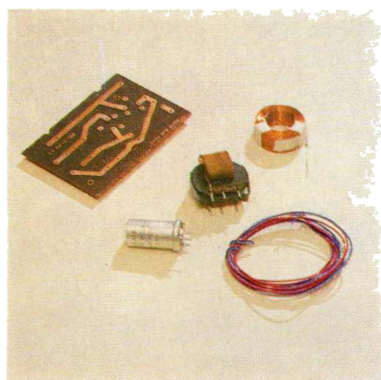

The printed-wiring board and components for the cross-over filter network. The wire is for connecting the speakers.

The assembled cross-over filter network. The screws and distance pieces can be seen. Failure to use the distance pieces to stand the printed-wiring board off the baffle may result in cracking the board.

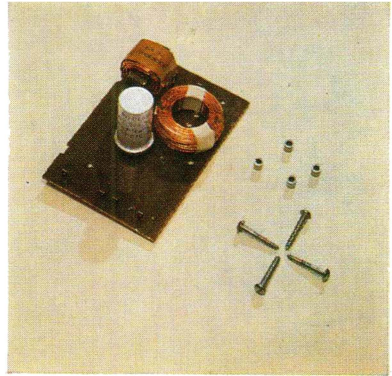

Connecting the speakers to the cross-over filter. The input lead is also attached at this stage. The small cut-outs for the tweeter tags are visible. The (+) connection of the speakers are marked with a red circle adjacent to the tag. The (-) connection is unmarked.

Screwing the enclosure together. The top and bottom and the two sides are fitted together by screwing-on the back. Plenty of glue should be used at the joints to ensure the enclosure is air-tight. Long panel pins driven in from the sides will help rigidity.

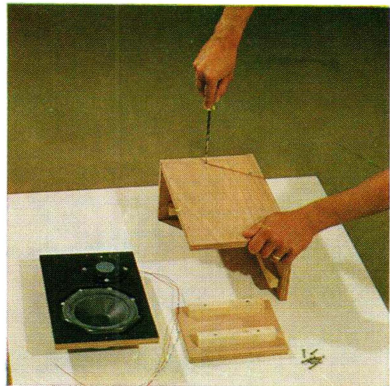

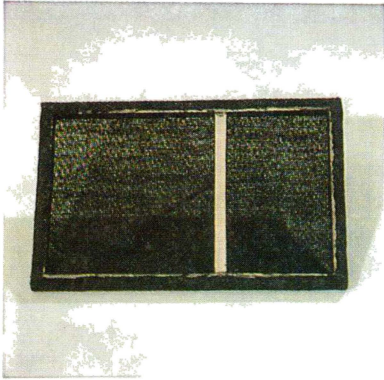

The completed grille cloth frame. The back of the frame need not be stained black. The cloth is glued to the frame and may be held in position by drawing pins while the glue hardens.

The acetate fibre lining fitted, the baffle board is screwed into position. Glue, or foam plastic strip, ensures air-tightness. Note the 20 mm deep recess to accomodate the grille frame.

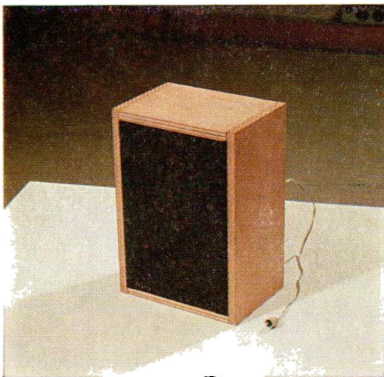
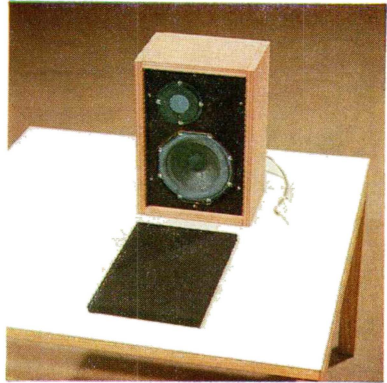

The completed enclosure with the grille frame in position. As the colour of the wood seen here is natural, a light application of French polish will produce an attractive finish.

5 Step-by-Step Construction of a 7-litre Enclosure

Step 1 Determining the Practical Dimensions

Consider the woofer, AD7065/W8. It has an octagonal frame and from page 56 one needs 156 mm to get it in the smallest width of baffle. From the form of construction of Fig. 9, one sees that two battens of 20 mm

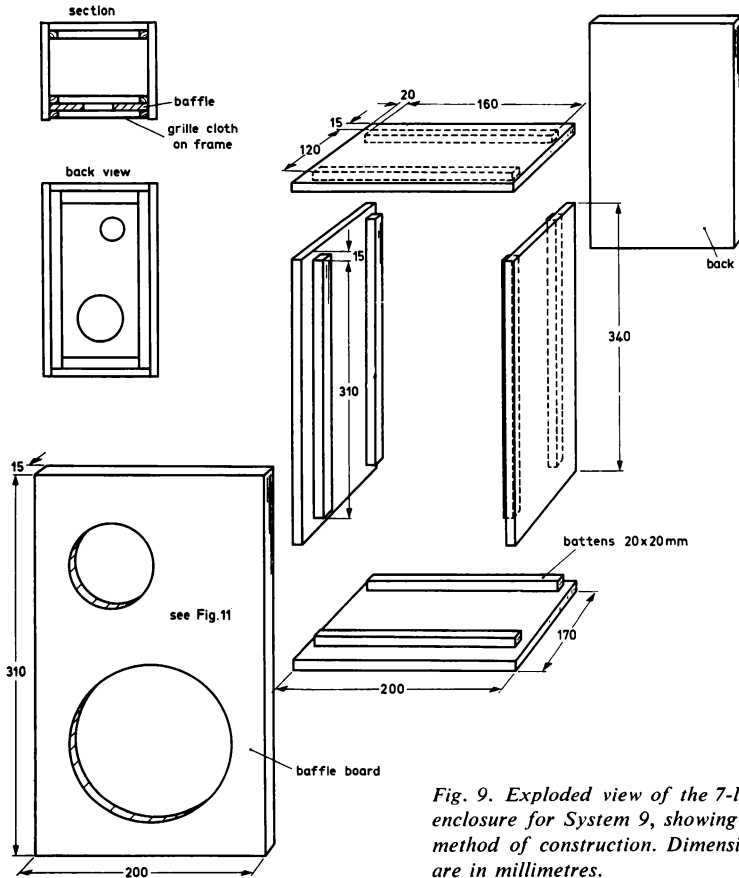

Fig. 9. Exploded view of the 7-litre enclosure for System 9, showing the method of construction. Dimensions are in millimetres.

square timber are used either side, so that no matter whether the woofer is mounted behind, or in front, of the baffle, the total inside width of the enclosure must be at *least* 200 mm. This will give an aspect ratio of 5 : 3 and a nice slim enclosure of pleasing appearance will result. Increasing the width will reduce the height correspondingly. The minimum enclosure depth must be $1\frac{1}{2}$ times the depth of the speaker and, from Table 4, this is 112 mm. Let us make it 120 mm, for as we shall see, we shall end up with a nice round sum for the final dimension of the side of the enclosure. Fig. 10 should make this clear.

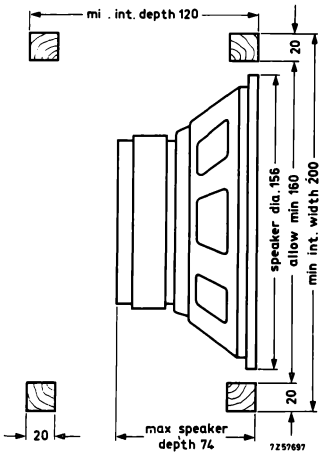
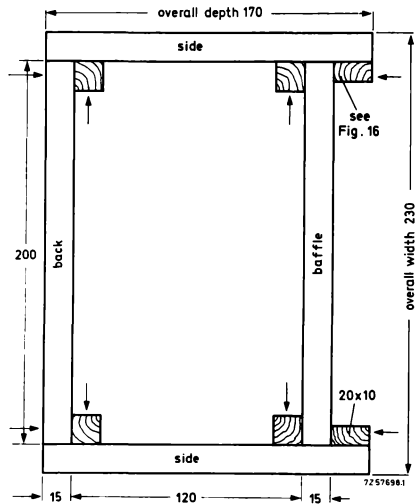

Fig. 10(a). Showing how the minimum internal dimensions of the enclosure are calculated.

Fig. 10(b). Showing how the overall dimensions are calculated. The small arrows indicate where the panels should be screwed to the battens. The only screw heads that will be visible after the enclosure is assembled are at the back and these can be covered with plastic wood, if desired.



Multiplying the internal width of 200 mm by the depth of 120 mm, we end up with 240 cm². The enclosure volume is to be 7 litres, or 7000 cm³, so if we divide this by 240 cm² we get a height of 291 mm. We should make it a little larger to give ourselves enough room for the tweeter and the filter, so let us use a length of 310 mm.

Our baffle board is, therefore, 200 mm wide and 310 mm long. The sides of the enclosure have to take into account the thickness of the material with which it is built. Here we are using 15 mm plywood, so the sides will measure 340 mm by 170 mm, and the top and the base will be 170 mm by 200 mm. Four long and four short battens of 20 mm square timber are required, in addition. The long ones will be the same as the length of the baffle board, that is, 310 mm, whilst the short battens will be 160 mm.

The speaker cloth is stretched over a frame of 20×10 mm timber and this frame is pushed into the front of the enclosure as a final touch. The frame requires two pieces 310 mm long and three pieces 180 mm long.

We are now able to prepare our timber cutting list, which should be as follows:

2 off	15 mm plywood	— 310 mm×200 mm	(Baffle and Back)
2 off	15 mm plywood	— 340 mm×170 mm	(Sides)
2 off	15 mm plywood	— 200 mm×170 mm	(Top and bottom)
4 off	20 mm square	— 310 mm long	(Long battens)
4 off	20 mm square	— 160 mm long	(Short battens)
2 off	20×10 mm	— 310 mm long	(Long frame)
3 off	20×10 mm	— 180 mm long	(Short frame)

Step 2 Laying-out the parts on the Baffle.

It is wrong to believe that an enclosure can be built and forgotten. Even speakers can get damaged by excessive overloads and therefore require replacement. If one has made a beautiful job of the enclosure and screwed and glued it, so that it is air-tight, nothing short of an axe will get it open again to change a speaker. No enthusiast who has gone through the experience of building his own enclosure will even contemplate using this method of servicing, so the answer is to build it in such a way that the speakers are not mounted behind the baffle, but *from the front*, so that they can be removed without attempting to dismantle the enclosure. A hole is cut in the baffle, the size of which will accommodate the speaker at its maximum diameter just *behind* the flange. The speaker

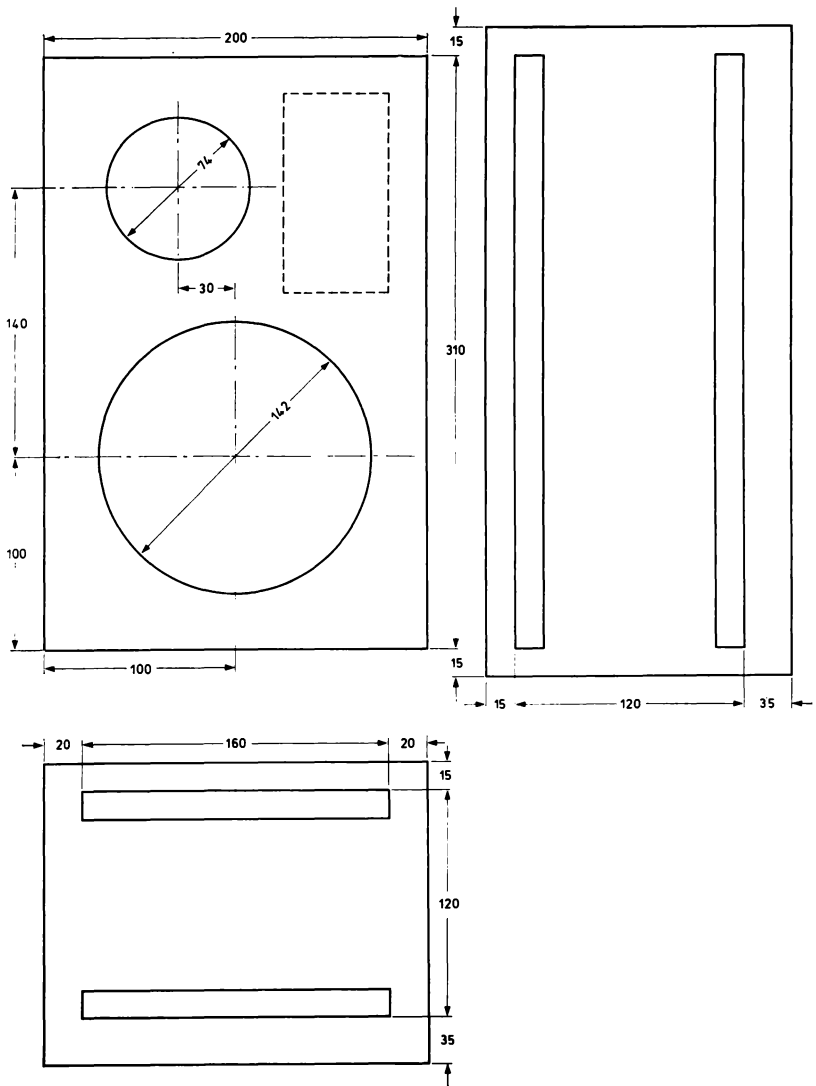

Fig. 11. Showing how the speakers and the cross-over filter are positioned on the baffle board and how the positions of the battens are determined.

then fits into this hole and can be secured by woodscrews, for example, from the front, the screws passing through the holes in the speaker frame first, and then into the baffle. To remove the speaker for servicing one has only to remove these screws and carefully withdraw the speaker from its hole, unsoldering the connecting wires.

The woofer is positioned on the baffle so that allowance for the thickness of the battens is made. The hole size for the speaker is 142 mm diameter, so half of this, plus 20 mm for the lower batten which runs across the bottom of the enclosure, gives a dimension of, say, 100 mm for the distance from the end of the baffle to the centre of the loudspeaker. This is shown in the suggested lay-out in Fig. 11.

We now come to the mounting of the tweeter. Firstly, this is a *professional* tweeter and it is normally mounted in a rather complicated counter-bored hole. Complicated, that is, for the home constructor to produce accurately. The method of doing this is shown in Fig. 12 and may be

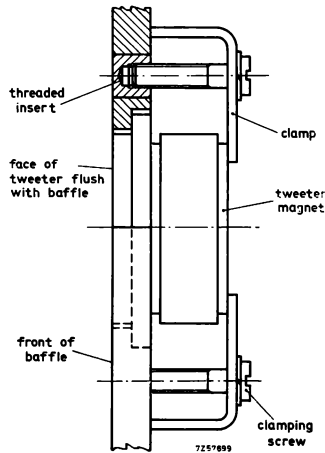

Fig. 12. The professional method of mounting the tweeter. The front face of the tweeter must NEVER lie behind the front of the baffle.

used by the reader if he wishes. A simpler method, which should appeal to those without special facilities for wood-machining, is to make a baffle hole 74 mm diameter, to accommodate the magnet system at the back of the tweeter, and screw the tweeter to the baffle from the front, using woodscrews. This is shown in Fig. 13.

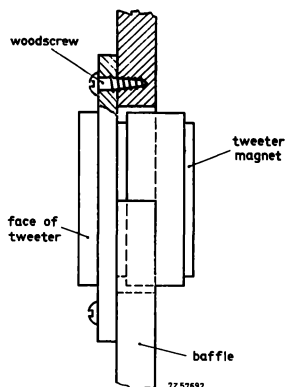

Fig. 13. A simple method of mounting the tweeter. Screws and nuts may be used, if preferred, instead of the woodscrews shown here.

The tweeter should be mounted above the woofer, to one side of the enclosure centre-line. It is suggested that a point 70 mm in from the sides forming the top left-hand corner be chosen. Fig. 11 makes this clear.

The above method of mounting leaves sufficient room for the cross-over filter which is mounted at the rear, next to the tweeter. It may be positioned anywhere, so long as it does not come within 20 mm of the edge, or it will foul the battens. It is not a good idea to screw the printed wiring board hard down to the rear of the baffle and the use of short distance-pieces is recommended.

Step 3 Fixing the Battens.

Take one of the panels measuring 200 mm by 170 mm and, using other pieces of timber as distance-pieces, screw and glue one of the 170 mm long battens to one of the 200 mm edges. There should be 15 mm space between the batten and the edge of the panel, and a 20 mm space at each end. Another similar batten is then attached to the other long edge, but this time there should be a 35 mm space between the batten and the edge of the panel. The completed panel can then be used for the top of the enclosure. The base of the enclosure is constructed in a similar way.

The panels measuring 340 mm by 170 mm are used for the sides of the enclosure, and the battens which are 310 mm long are screwed and glued to them in the same relative positions as for the top and bottom.

Step 4 Assembling the Cross-over Filter.

The circuit of the cross-over network, given in Fig. 14, shows how the components for the filter are connected together. Since a printed-wiring board was available all that had to be done was to insert the component connections into the appropriate holes in the printed-wiring board and solder them quickly, without prolonged application of heat. If the reader is not familiar with the art of soldering, it should not be too difficult to obtain some assistance in this matter.

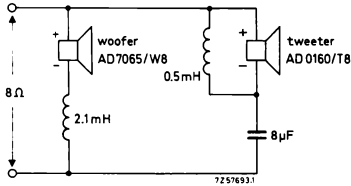

Fig. 14(a). Circuit diagram of the cross-over filter network, showing where the speakers are connected.

Fig. 14(b). The printed-wiring board which was used for the cross-over filter.

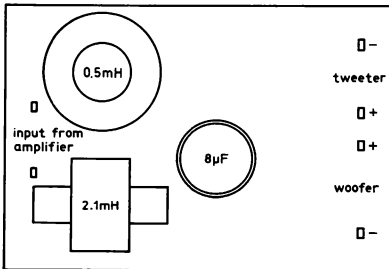
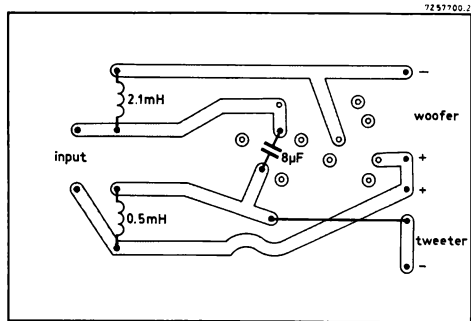
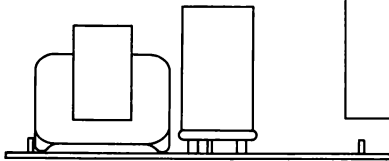

Fig. 14(c). Showing the layout of the components on the printed-wiring board. Note that the 0.5 mH coil is air-cored.

Step 5 Preparing the Baffle Board.

After the baffle holes have been cut, smooth the edges of the holes with a rasp, then when there is no chance of dirt getting into the speakers, lower them into their respective holes and mark out the positions for the screws. Remove the speakers and use a bradawl, or a small drill, to make a pilot hole for the woodscrews.

For the tweeter, the two 'ears' at opposite sides of the hole should be cut out with a rasp to accommodate the connection tags as shown in Fig. 15

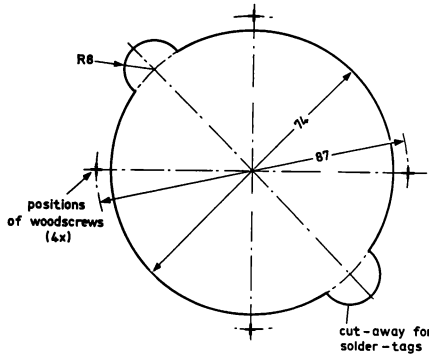

Fig. 15. Details of the baffle hole for the tweeter.

and then a length of approximately 20 cm of insulated connecting wire soldered to each of the tags. Drill and countersink the holes for the woodscrews that fix the baffle to the battens.

Next, paint or stain the baffle board black on the front side, since this is the colour of the speakers, otherwise they could be visible through the speaker grille cloth after it has been fitted. A bottle of dye for black suede shoes is recommended, as it is not sticky and dries very rapidly with an even matt finish.

Attach strips of 10 mm wide adhesive plastic-foam, such as is used for draught-proofing, around the back of the tweeter flange, where it will come into contact with the baffle. This is also carried out on the woofer. The plastic-foam strip is used to help to keep the enclosure air-tight, and can be stuck to the baffle instead, if the reader wishes.

Step 6 Assembling the Components on the Baffle Board.

The woofer and tweeter are now screwed into position. Plain washers are first placed on the screws and the screws are tightened up carefully. Do not tighten any screw completely before going on to the next. A gradually increasing pressure should be obtained by tightening each screw, in turn, a little more until all are quite firm. Failure to observe this precaution could result in bending the woofer frame, or breaking the flange of the tweeter. Do not overtighten!

Solder a 20 cm length of insulated connecting wire to each of the woofer connections. Attach the printed-wiring board to the rear of the baffle with woodscrews, not forgetting the distance pieces which have been recommended; 5 mm diameter tubing can be used.

To ensure that the speakers are correctly phased, it should be noted that one connection of each speaker has a red mark adjacent to it. This is the (+) connection shown on the filter circuit for System 9 on page 37 and the speakers should be connected accordingly. Solder a 50 cm long wire to each of the filter input tags, bare the ends of the wires and **CONNECT THEM TO THE AMPLIFIER**. With the volume well down, so that no damage can occur to the speakers, check that both the tweeter and the woofer are working correctly.

Step 7 Assembling the Enclosure.

Hold the sides, the top and the bottom together and check that both the baffle and the back panel just fit neatly into the recesses formed at the front and rear. Drill and countersink the holes for woodscrews in the back and start assembly by screwing and glueing the back to one of the side pieces. Next the top, then the other side and, finally, the base. A small hole should then be drilled in the back for the connecting leads. Fibreglass, or similar damping material, is then used to line the inside of the enclosure. A suitable adhesive, depending on the material, may be employed, or nails may be used, with washers under their heads. Adhesive should be applied along the edges of the panels and also the battens where they come into contact with one another during assembly. Anything the reader can do to improve the air-tightness of the enclosure is to be welcomed. Thin headless nails, or long panel pins may be driven through the sides into the top and bottom panels for additional strength.

Before the baffle is fitted, the input wires are passed through the small hole in the rear of the enclosure and fixed to a terminal strip, or socket,

whichever the reader prefers. Any holes or gaps in the enclosure should be closed with wood-filter. When this has dried it should be smoothed-down with glass-paper, care being taken to prevent the dust going into the tweeter. The baffle is then screwed into position.

When the above has been completed, the five 20×10 mm strips are pinned-together to make a frame for the cloth, as shown in Fig. 16.

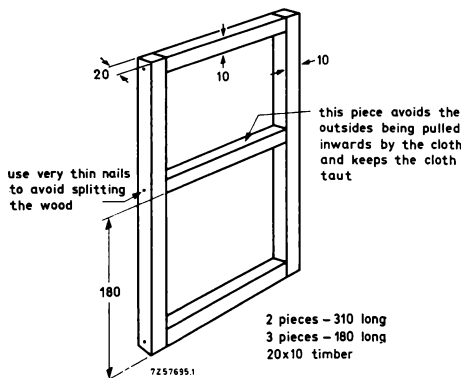

Fig. 16. Showing how the frame for the grille cloth is assembled. Make sure that the piece of cloth is cut large enough to wrap around the frame at the edges. Stain the front and inside of the frame black before fitting the grille cloth.

Adhesive is applied to the frame and the cloth is then stretched over it and secured with drawing pins, until the adhesive has set. The completed frame should be a *push fit* inside the front of the enclosure. If desired, 20 mm thick plastic foam may be used to fill the vacant spaces between the grille cloth and the baffle board — not in front of the speakers, of course!

We have not been specific about the kind of woodscrews to be used but we recommend round-headed screws for fixing the speakers and countersunk-headed screws for the baffle and the back panel. The batens may be fixed to the panels with either type of woodscrews. If the reader wishes, he may make a deeper countersink in the back panel so that when the screws have been tightened, the head of the screw may be obscured with plastic wood. When dry, this can be smoothed-off with glass-paper.

The final finish of the enclosure is left to the discretion of the reader. It may be stained and French-polished, cellulose-sprayed, veneered, painted, or covered with self-adhesive plastic sheet.

6 Constructional Details of 24 Speaker Systems

The principles of calculating the dimensions of the materials for constructing an enclosure should now be clear to the reader and little difficulty should be experienced in designing an enclosure to suit his individual requirements.

In Chapter 3 we gave electrical details of 24 speaker systems. This Chapter is devoted to their constructional details and baffle board layouts are suggested which will produce enclosures with an aspect ratio of 5 : 3.

Fig. 17 gives the principal internal dimensions of the family of 11 enclosures which will house the 24 speaker systems. It should be noted that whilst the baffle board dimensions remain in the same proportion, this does not apply to the depths of the different enclosures. For example, compare the two 7-litre enclosures where the one for Systems 9 and 10 is not as deep as that for Systems 5, 6, 7 and 8. The reason is that for Systems 9 and 10 the one inch tweeter has been used and, since this is a sealed unit, no acoustic isolating box is necessary. To avoid the larger enclosures becoming unduly deep because the Ticonal magnet systems of the 10" and 12" woofers are longer, the full depth of the speaker has not been used, only the depth of the cone being taken into account in calculating the depth of the 35, 40, 50 and 80 litre enclosures, as described on page 56.

The dimensions of the materials to make the enclosures, using the form of construction of Fig. 18, are given in Table 5. Baffle board layouts, *viewed from the rear*, are shown in Figs. 19 to 29 and the position of the front battens and the walls of the isolating boxes can be clearly seen. But it does not matter which way round the baffle board is used, i.e. if the tweeter is on the left or right-hand side of the centre-line.

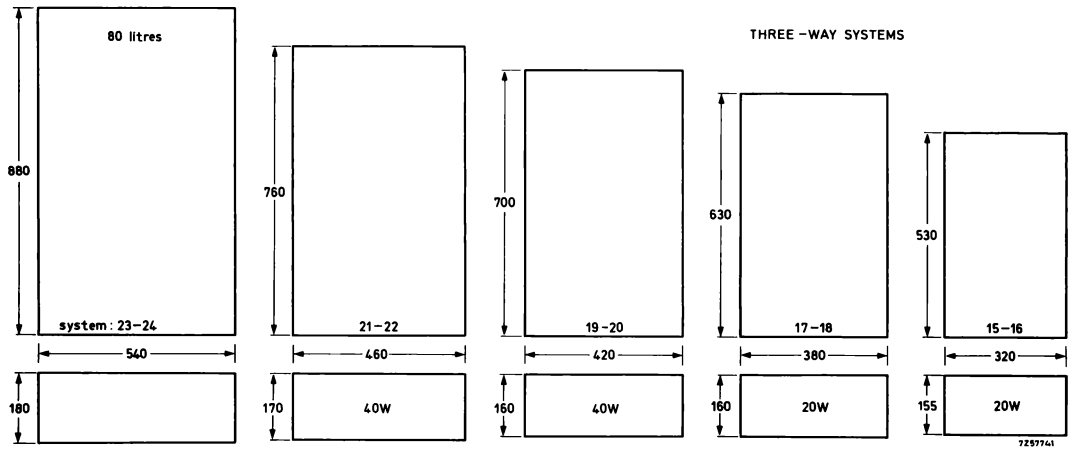
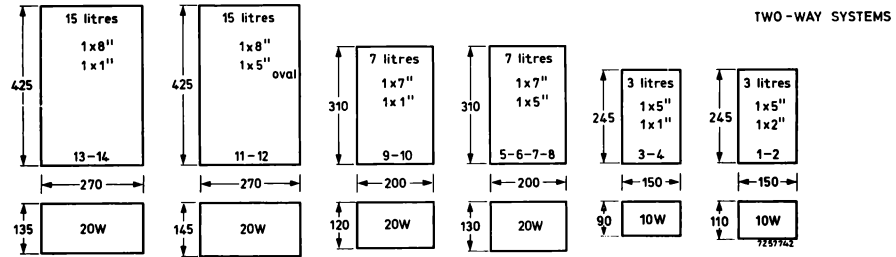

Fig. 17. Leading particulars of the 24 speaker systems. Sizes given are internal dimensions in millimetres.

Table 5. Dimensions for Materials to Build the Recommended Enclosures.

system number	baffle layout	dimensions for Fig. 18											
		A	B	C	D	E	F	G	H	J	K	L	M
1, 2	Fig. 19	10	245	150	110	10	150	150	265	110	245	10	20
3, 4	Fig. 20	10	245	150	90	10	130	150	265	110	245	10	20
5, 6, 7, 8	Fig. 21	15	310	200	130	15	180	200	340	160	310	15	20
9, 10	Fig. 22	15	310	200	120	15	170	200	340	160	310	15	20
11, 12	Fig. 23	20	425	270	145	20	205	270	465	230	425	20	20
13, 14	Fig. 24	20	425	270	135	20	195	270	465	230	425	20	20
15, 16	Fig. 25	20	530	320	155	20	215	320	570	280	530	20	20
17, 18	Fig. 26	25	630	380	160	25	230	380	680	340	630	25	20
19, 20	Fig. 27	25	700	420	160	25	230	420	750	380	700	25	20
21, 22	Fig. 28	25	760	460	170	25	240	460	810	420	760	25	20
23, 24	Fig. 29	25	880	540	180	25	250	540	930	500	880	25	20

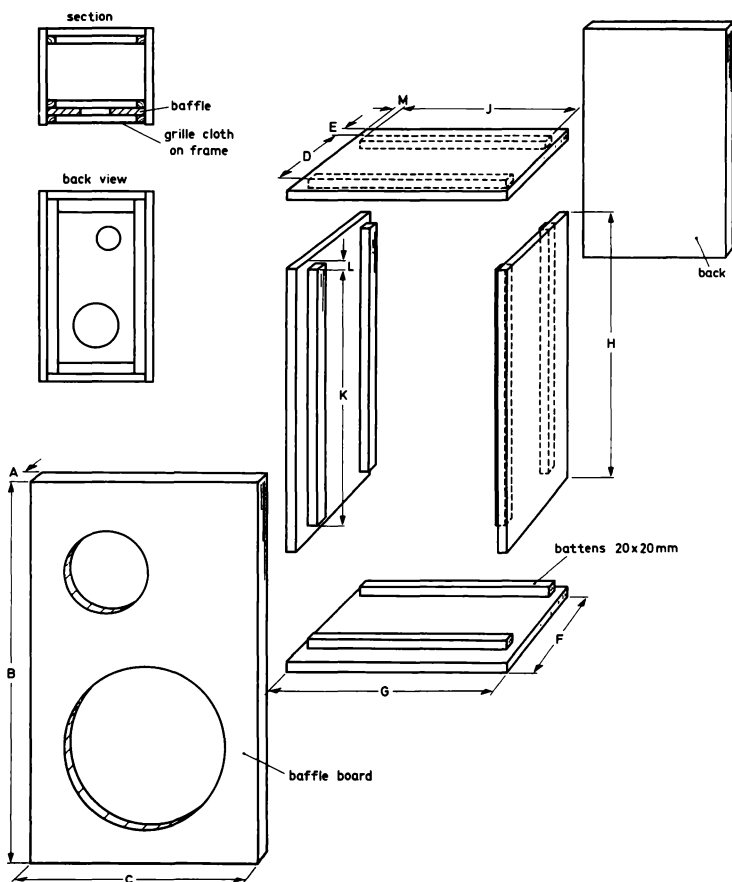

Fig. 18. Standard form of construction of the recommended enclosures. See Table 5 for dimensions. The thickness of the baffle board, shown as dimension A, applies to all the panels. Battens of 20 mm square timber are used on each enclosure. The grille cloth frame is made of 20 × 10 mm timber in every case.

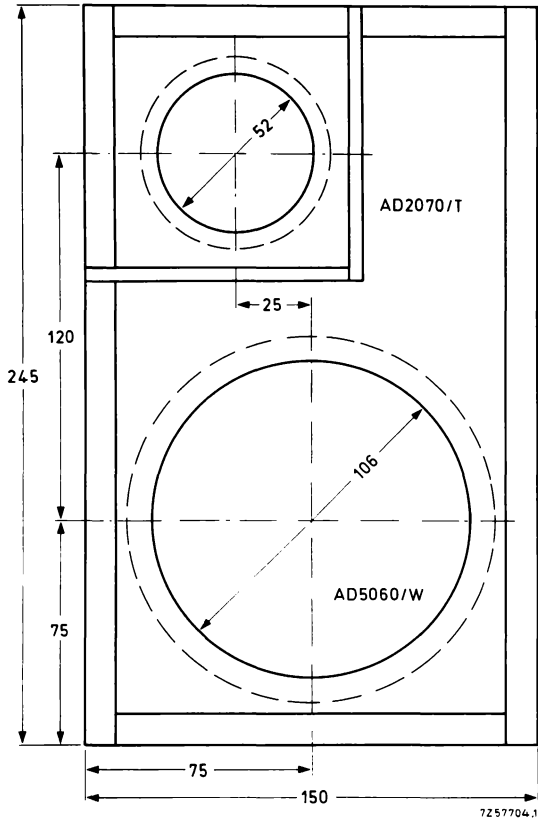

Fig. 19. Baffle board layout for Systems 1 and 2.

Enclosure volume = 3 litres; internal depth = 110 mm; tweeter box inside dimensions = 60×60×16 mm, with 5 mm walls.

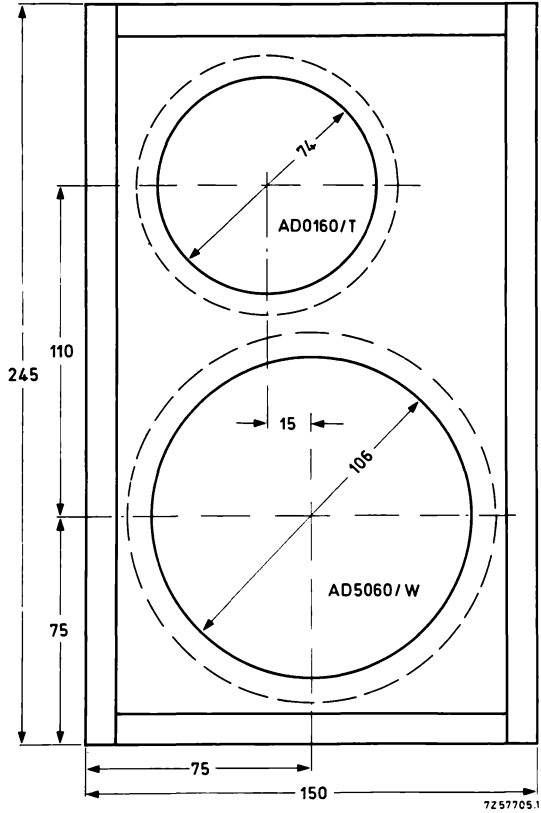

Fig. 20. Baffle board layout for Systems 3 and 4.

Enclosure volume = 3 litres; internal depth = 90 mm.

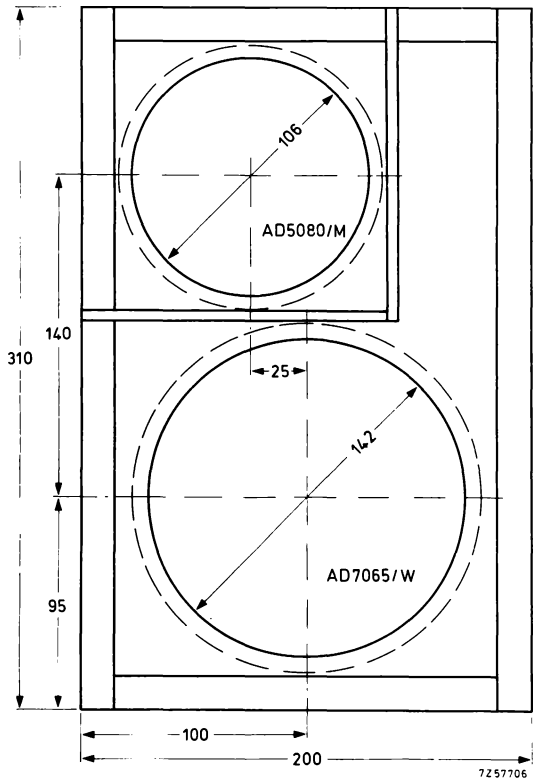

Fig. 21. Baffle board layout for Systems 5, 6, 7 and 8.

Enclosure volume = 7 litres; internal depth = 130 mm; tweeter box inside dimensions = 110×110×30 mm, with 5 mm walls.

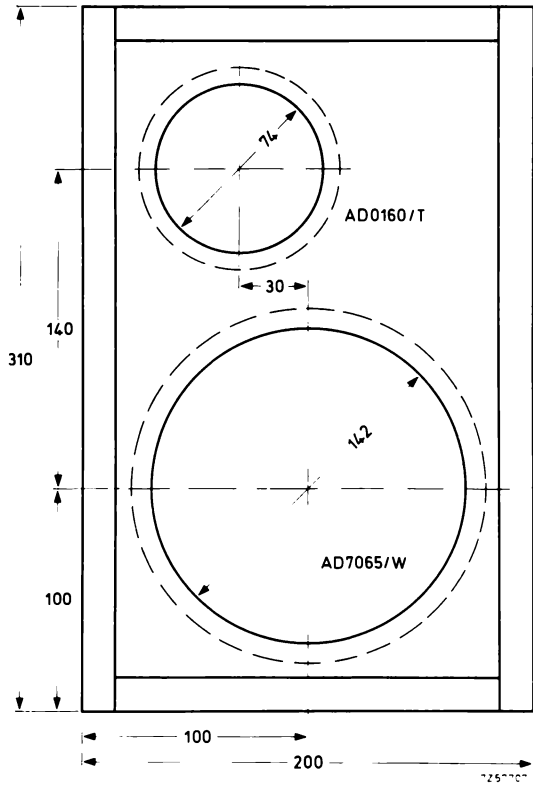

Fig. 22. Baffle board layout for Systems 9 and 10.

Enclosure volume = 7 litres; internal depth = 120 mm.

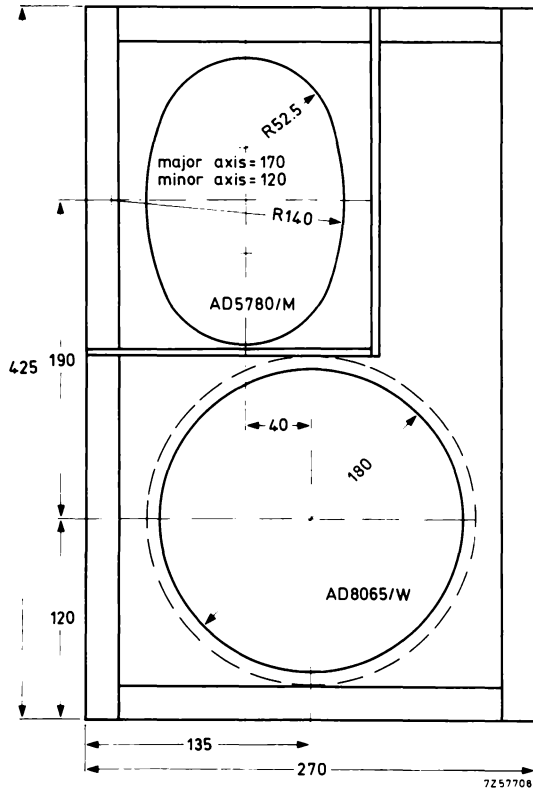

Fig. 23. Baffle board layout for Systems 11 and 12.

Enclosure volume = 15 litres; internal depth = 145 mm; tweeter box inside dimensions = $180 \times 140 \times 35$ mm, with 5 mm walls.

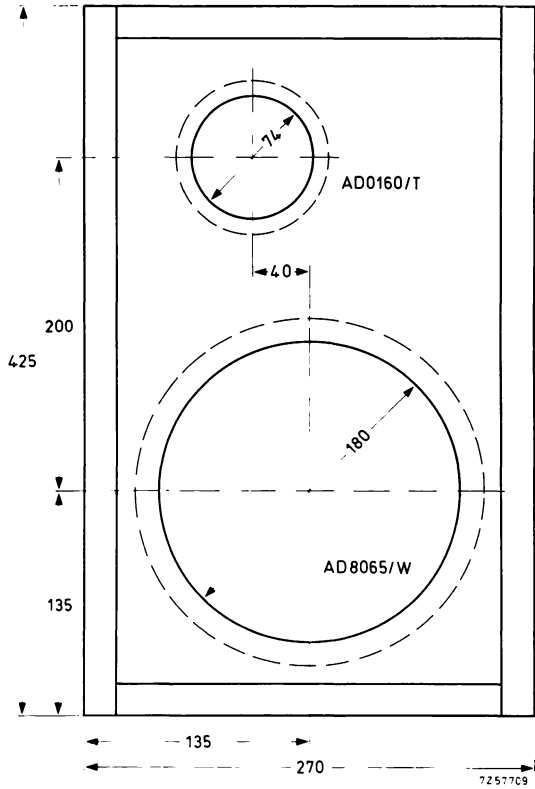

Fig. 24. Baffle board layout for Systems 13 and 14.

Enclosure volume = 15 litres; internal depth = 135 mm.

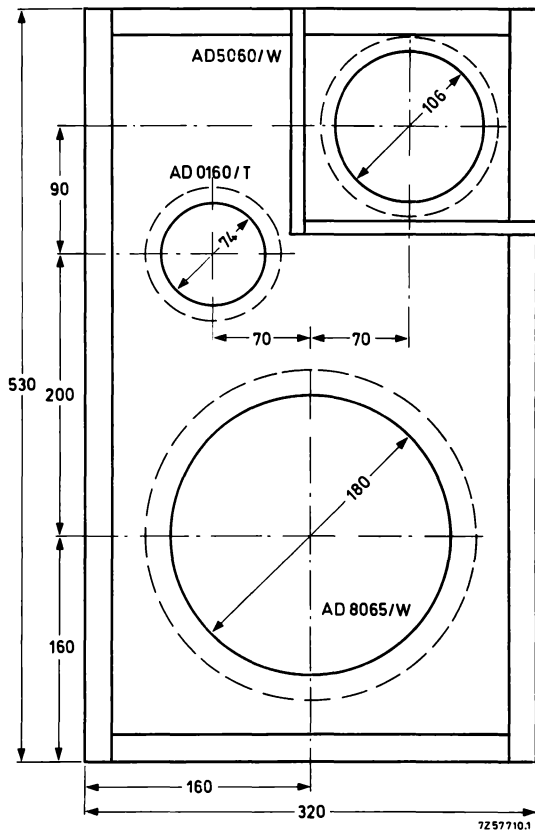

Fig. 25. Baffle board layout for Systems 15 and 16.

Enclosure volume = 25 litres; internal depth = 155 mm; squawker box inside dimensions = 155 × 120 × 60 mm, with 10 mm walls.

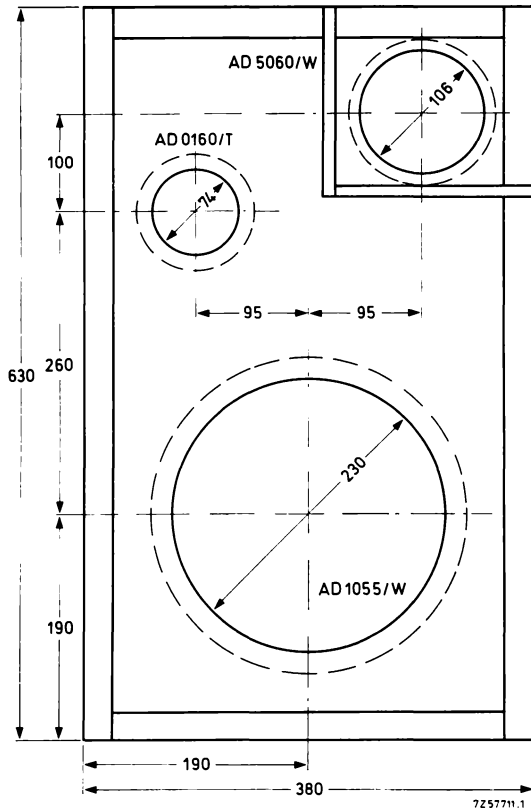

Fig. 26. Baffle board layout for Systems 17 and 18.

Enclosure volume = 35 litres; internal depth = 160 mm; squawker box inside dimensions = $185 \times 120 \times 60$ mm, with 10 mm walls.

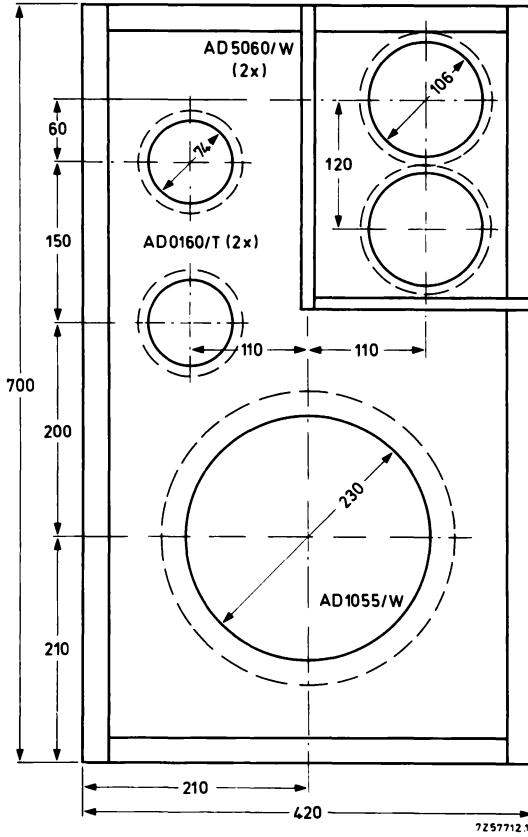

Fig. 27. Baffle board layout for Systems 19 and 20.

Enclosure volume = 40 litres; internal depth = 160 mm; squawker box inside dimensions = 240 × 205 × 60 mm, with 10 mm walls.

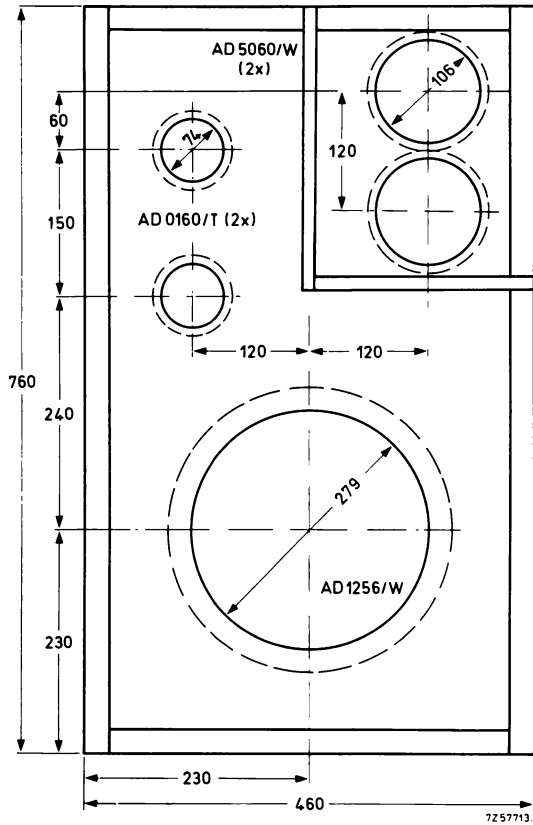

Fig. 28. Baffle board layout for Systems 21 and 22.

Enclosure volume = 50 litres; internal depth = 170 mm; squawker box inside dimensions = 240 × 222 × 60 mm, with 15 mm walls.

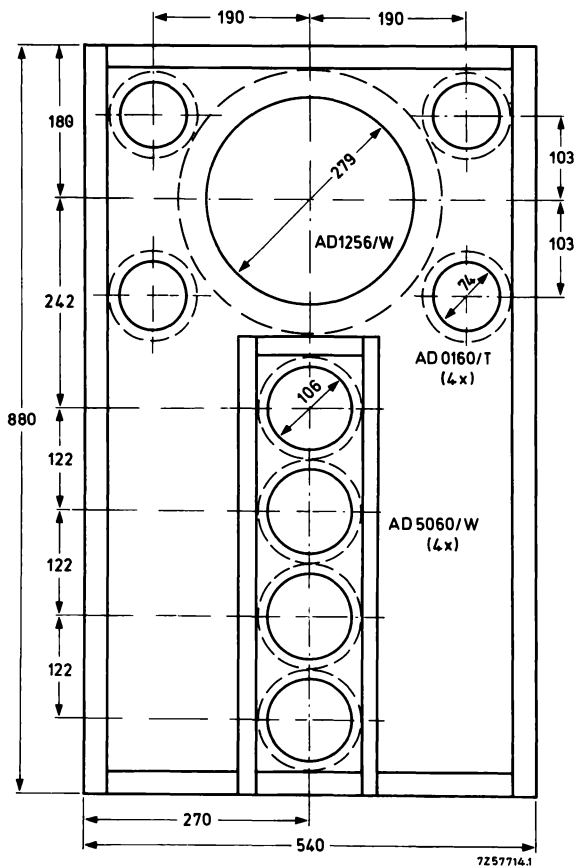

Fig. 29. Baffle board layout for Systems 23 and 24.

Enclosure volume = 80 litres; internal depth = 180 mm; squawker box inside dimensions = 480 × 120 × 60 mm, with 20 mm walls.

7 Listening Room Acoustics

7.1 Absorption and Reverberation

For most readers the opportunity to influence the distribution of the sound output from the speaker is very limited, but it is quite important to understand the factors which affect the sound quality, nevertheless. In the living room, the sound waves can travel only a short distance before they strike some object. They are reflected and some of the energy contained in them is dissipated by absorption so that the energy in the wave gets progressively less and less. The time taken for the sound energy to fall to one-millionth of its original value is known as the “reverberation time”. It depends on the size of the room, but about half a second is considered satisfactory for listening to reproduced music, and this applies to the middle frequencies.

Not only do the various materials of the floor, walls and ceilings absorb energy, but so also do the normal furnishings of the room and the listeners themselves. Modern furnishings tend to utilize materials which do not absorb sound readily, particularly glass, which is one of the worst materials acoustically. Large windows are, nevertheless, very desirable.

Only limited improvements can be made to the living room acoustics. Thick carpet with foam rubber underlay is probably the best for floor covering and, where choice of a suitable room is involved, solid floors are better than wood boards supported on joists. Where the reader would like to have greater absorption in the high and middle frequency ranges he can make use of acoustic tiles which can be fixed in strategic positions on ceilings and walls. The advice of an expert on acoustics should be sought before this is undertaken. Any experiments which are conducted by the reader should be done with the tone controls of the equipment set at ‘flat’. When the reader has reached the stage where no further improvement in the sound quality can be made by modifying the room acoustics, the effect of the tone controls can then be tried.

7.2 Room Resonances

Where any dimension of the room is one-half the wavelength of the sound, resonant vibrations will be excited in the air. At a frequency of

40 Hz, the wavelength of the sound is 8.5 metres, so the length of the room which will resonate at that frequency will be half that, that is, 4.25 metres (14 feet). In addition there are harmonics of this frequency; the second harmonic at 80 Hz, and the third harmonic at 120 Hz. Not only does this apply to the length of the room, but resonances will occur at many frequencies due to the height and width, and diagonal dimensions as well. Where one of the dimensions of the room is nearly an exact multiple of the other, the fundamental resonance frequency of one dimension of the room will modulate a harmonic of the resonance frequency of the other dimension and the whole picture becomes very complex. All this gives rise to “standing waves” which create increases in sound pressure at certain regions in the room.

Obviously little can be done, without calling the builders to change the shape of the room to alleviate the resonances but, whatever the proportions of the room, any broken surfaces or projections will give some improvement. Advantage can often be taken of the use of ‘room-dividers’ and free-standing bookshelves of the modern design.

7.3 Positioning of Speakers

The golden rule for positioning of speakers is DO NOT OBSCURE THE BAFFLE. It is useless to construct a high quality enclosure, stand it on the floor behind a chair and then expect it to perform satisfactorily. It is well known that a corner position for the speaker helps bass performance, but it does not necessarily follow that this will activate room resonances in the best way. Only experimenting will provide the final answer.

Where stereo is concerned the problem is increased. Now there will be two speakers and, where the enthusiast has one to make up for the “hole-in-the-middle”, sometimes three. These speakers have to bear a sensible relationship to one another in their positioning, otherwise the advantage of stereo is lost. Again, only experimenting will provide the answer.

7.4 Blaming Your Speakers

It is so easy to blame the speakers when the desired performance is not obtained. Speakers can be to blame, but not very often. One very common occurrence is where people try to use too big a loudspeaker in a tiny flat, and spend most of their time boosting the bass on the amplifier.

THE ROOM HAS THE FINAL WORD, not the speaker, since the lowest frequency that will be satisfactorily reproduced is that which has a half wavelength corresponding to the largest dimension of the room, its diagonal, as shown in Fig. 30. Below that frequency the response falls off very rapidly, so check against Table 6.

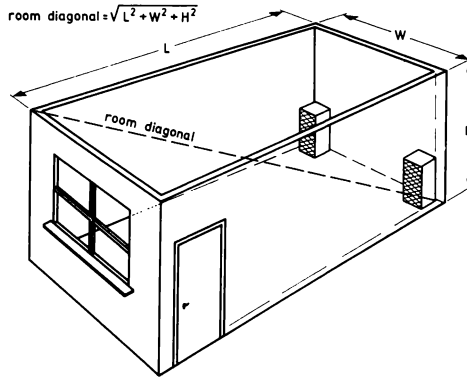

Fig. 30. Low frequency cut-off occurs when the room diagonal becomes half the wavelength.

Table 6. Listening Room Bass Cut-off.

room diagonal (= $\lambda/2$)		cut-off frequency
(metres)	(feet)	(Hz)
8.5	28	20
6.8	22.4	25
5.66	18.5	30
4.85	15.9	35
4.25	14	40
3.78	12.4	45
3.4	11.2	50
2.83	9.2	60
2.13	7.0	80
1.7	5.6	100

To avoid room resonances, moving the chair may take the listener out of a region of pressure maximum and overcome a certain “boominess” which may be blamed on the speaker. Similarly, moving a speaker may excite different room resonances and the result may be preferable to the original positioning. See Table 7.

Table 7. Wavelength of Sound.

frequency (Hz)	wavelength		frequency (Hz)	wavelength	
	(m)	(in)		(mm)	(in)
100	3.4	134	2500	136	5.3
150	2.26	82	3000	113	4.5
200	1.7	67	4000	85	3.4
300	1.13	45	5000	68	2.7
400	0.86	34	8000	42.5	1.7
500	0.68	28	10000	34	1.3
800	0.43	16.8	12000	28	1.1
1000	0.34	13.2	15000	23	0.88
1500	0.23	8.9	18000	19	0.74
2000	0.17	6.7	20000	17	0.66

For stereo the outputs of the speakers must be in phase, otherwise the illusion will be lost. Standing in a central position, the listener should get the impression that the sound comes from a point mid-way between the speakers. If the sound appears to separate itself into two sources, the connections to one of the speakers should be reversed.

7.5 The Latest Thing in Sound—Mono

Stereo appears to be everywhere. Pre-recorded tapes provide the listener with the most satisfactory source of stereo programmes, gramophone records being only a second-best source, but a very good second-best, nevertheless. The reader who has only a single channel installation may feel that he is the last remaining listener to such programmes and wonders how long he will still be able to buy the recordings! Let us assure the reader that good quality mono is infinitely better than poor quality stereo and, furthermore, there is quite a lot that the mono enthusiast can do with his installation which the stereo man cannot. There are many stereo readers who will appreciate that stereo carries with its ownership the

double responsibility for driving the system properly; there are twice as many things to go wrong, and once the system has been installed, it is fairly inflexible.

The mono man can enjoy a whole range of speakers, suitably connected with regard to power considerations and impedance matching, in which the frequency range can be split-up to give a wide panorama across the frequency spectrum, with a measure of pseudo-stereophony. From the listener's point of view not much experimenting can be carried out with a stereo installation or the effect will be spoiled, and there are many stereo fans who envy the mono enthusiast, for he can switch-in speakers in all directions to produce different effects.

Even the stereo fan should try playing a mono record sometime, it's the latest thing in sound!

7.6 Psychedelic Sound and The Future

Hearing is only one of the senses. Seeing plays an unexpected part in listening, also. Watch a person's mouth when he is speaking and consider how much easier it is to 'hear'. Is one lip-reading, as well? View the television and consider what the sound quality is really like — then shut your eyes and consider it again. We know the reproduction cannot be very high quality, because of the type of speaker used, but was it really obvious when the picture was being viewed at the same time?

Together, sound and vision make tremendous impact on the senses and the familiar *Son et Lumière* displays are a typical example of the popular appeal of this form of entertainment. Dramatic effects can be produced which stimulate the imagination and bring with it that sense of fantasy sought by music lovers all the world over. Not only music lovers, we might add, for the young seek after excitement in a dream-world where only beautiful things exist. This dream-world can be synthesized by music and exotic colours and the combination of the two produces the psychedelic effects which stimulate this fantasy in the imagination.

Sound reproduction has reached a very high standard at the present time and many readers will appreciate that it is difficult to visualize how many further improvements are possible. Perhaps we shall see a new generation of equipment designed to compensate for the inadequacies of our listening conditions, with yet more controls to help us counteract its deficiencies and variability. Five hundred identical installations may all

sound different because of the different listening rooms in which they operate.

Perhaps we may one day see equipment with controls marked like this:

<i>Curtains</i>		<i>Carpet</i>	
Position 1	No Windows	Position 1	Fitted, Wool
2	Velvet	2	Fitted, Synthetic
3	Tapestry	3	Part, Wool
4	Linen	4	Part, Synthetic
5	Net	5	Lino
6	Bare Windows	6	Bare Boards

<i>Room</i>	<i>Volume (m³)</i>	<i>Speaker Height (cm)</i>	<i>Programme Material</i>		
Position 1	300	Position 1	150	Position 1	Concert Orchestra
2	200	2	100	2	Dance Band
3	100	3	75	3	Octet
4	50	4	50	4	5-Piece
5	25	5	25	5	Solo Instrument
6	10	6	15	6	Vocalist

Or, maybe not! Controls are not everything and the reader should remember that a simple installation is often the best.

In search for greater realism, 4-channel stereo is making its mark. Obviously four entirely separate channels are required, and that means four of everything — pre-amplifiers, power amplifiers and speaker systems. Programme material is not readily available at present, but two systems are now under development; tape and disc. The tape system uses 4-track tape and a 4-track head-stack. One disc system employs the usual 45°/45° method of recording, but each “track” contains the signals for two channels, coded together. A decoder is employed to separate the “front” and “rear” signals of each channel. Four loudspeaker systems are required.

Whatever the future of sound reproduction, or the use to which it is put, either in its own right, or in combination with other stimuli, the goal of high fidelity enthusiasts, the world over, is for greater and greater *perfection*. In this book we have tried to guide the interested reader in his choice of loudspeakers and how to use them. We hope that he is going to build some of the enclosures we have recommended, anyway. And we hope he has a pleasant journey. If, despite all we have said, the reader decides *not* to follow our recommendations, may we suggest headphones?

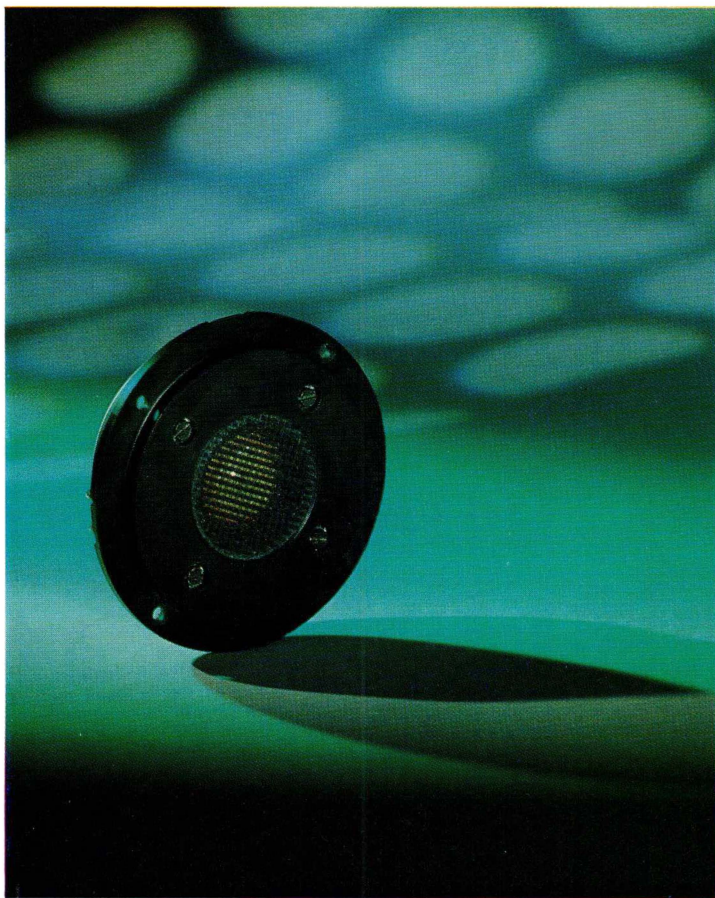

The one-inch "dome" tweeter gives superb reproduction of all frequencies from 1,000 Hz to over 20,000 Hz. It has a dome-shaped diaphragm which gives a nearly ideal polar diagram and because of the low mass of its moving parts transient distortion is negligible.

Indonesia

P.T. Philips-Ralin Electronics
Elcoma Division
Djalan Gadjah Mada 18
Tel. 44 163
DJAKARTA

Ireland

Philips Electrical (Ireland) Pty
Newstead Clonskeagh
Tel. 69 33 55
DUBLIN 6

Italy

Philips S.p.A.
Sezione Elcoma
Piazza IV Novembre 3
Tel. 69.94
MILANO

Japan

NIHON PHILIPS
32nd Fl. World Trade Center Bldg.
5, 3-chome, Shiba Hamamatsu-cho
Minato-ku,
Tel. (435) 5204-5
TOKYO

Mexico

Electrónica, S.A. de C.V
Varsovia No. 36
Tel. 5-33-11-80
MEXICO 6, D.F.

Netherlands

Philips Nederland N.V.
Afd. Elonco
Boschdijk, VB
Tel. (040)-43333
EINDHOVEN

New Zealand

EDAC Ltd
Kingsford Smith Street
Tel. 873159
WELLINGTON

Norway

Electronica A/S
Middelthunsgate 27
Tel. 46 39 70
OSLO 3

Peru

CADESA
Av. Abancay 1176
Tel. 773 17
LIMA

Portugal

Philips Portuguesa S.A.R.L.
Rua Joaquim Antonio de Aguiar 66
Tel. 68 31 21/9
LISBOA

South Africa

EDAC (Pty) Ltd.
South Park Lane
New Doornfontein
Tel. 24-20-47
JOHANNESBURG

Spain

COPRESA S.A.
Balmaes 22
Tel. 2320300
BARCELONA 7

Sweden

ELCOMA A.B.
Lidingövägen 50
Tel. 08/679780
Fack STOCKHOLM 27

Switzerland

Philips A.G.
Edenstrasse 20
Tel. 051/442211
CH-8027 ZUERICH

Taiwan

Philips Taiwan Ltd.
Plastic Building, 10th Floor
Nanking East Rd., 2nd Section
Tel. 55 97 42
TAIPEI

Turkey

Türk Philips Ticaret A.S.
EMET Department
Gümüssuyu Cad. 78-80
Tel. 447480
Beyoğlu, ISTANBUL

United States

Amperex Electronic Corp.
Electronic Components Div
Tel. 516-234-7000
HAUPPAGE N.Y.

Uruguay

Luzilectron S.A.
Rondeau 1567, piso 5
Tel. 9 43 21
MONTEVIDEO

Venezuela

Philips Venezolana S.A
Elcoma Department
Apartado 1167
Tel. 72.01.51
CARACAS

Technology relating to the products described in this publication is shared by the following companies:

Argentina

FAPESA I.y.C.
Melincué 2594
Tel. 50-9941/8155
BUENOS AIRES

Australia

Philips Industries Ltd.
Miniwatt Electronics Division
20, Herbert St.
Tel. 43-2171
ARTARMON, N.S.W.

Austria

WIVEG
Zieglergasse 6
Tel. 93 26 22
1072 WIEN

Belgium

M.B.L.E.
80, Rue des Deux Gares
Tel. 230000
1070 BRUXELLES

Brazil

IBRAPE S.A.
Rua Manoel Ramos Paiva 506
Tel. 93-5141
SAO PAULO

Canada

Philips Electron Devices
116 Vanderhoof Ave.
Tel. 425-5161
TORONTO 17, Ontario

Chile

Philips Chilena S.A.
Av. Santa Maria 0760
Tel. 39 40 01
SANTIAGO

Colombia

SADAPE S.A.
Calle 19, No. 5-51
Tel. 422-175
BOGOTA D.E. 1

Denmark

Miniwatt A/S
Emdrupvej 115
Tel. (01) 69 16 22
DK-2400 KØBENHAVN NV

Finland

Oy Philips A.B.
Elcoma Division
Kaivokatu 8
Tel. 10 915
HELSINKI 10

France

R.T.C. - La Radiotechnique-Compelec
Avenue Ledru Rollin 130
Tel. 797-99-30
PARIS 11

Germany

VALVO G.m.b.H.
Valvo Haus
Burchardstrasse 19
Tel. (0411) 339131
2 HAMBURG 1

Greece

Philips S.A. Hellénique
Elcoma Division
52, Av. Syngrou
ATHENS

Hong Kong

Philips Hong Kong Ltd.
Components Dept.
St. George's Building, 21st Fl.
Tel. K-42 82 05
HONG KONG

India

INBELEC Div. of Philips India Ltd.
Band Box Building
Post Box 391
254-D, Dr. Annie Besant Road
Tel. 45 33 86, 45 64 20, 45 29 86
Worli, BOMBAY 18 (WB)

AD 5780/M

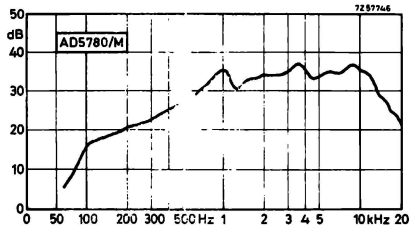
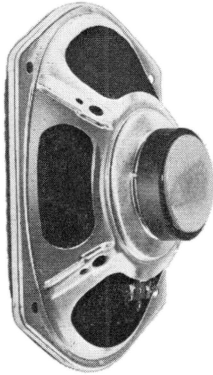

5" x 7" Standard Loudspeaker

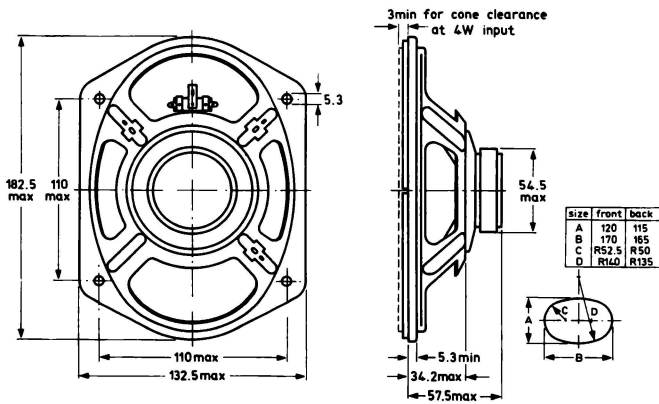

*Two Speakers from the Standard Range
Recommended for High Frequency Duty*

AD 5080/M

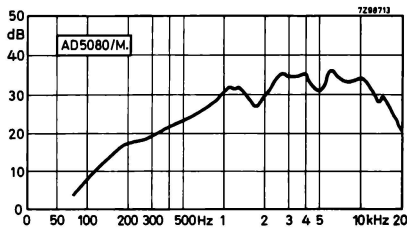
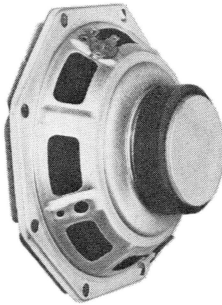

5" Standard Loudspeaker

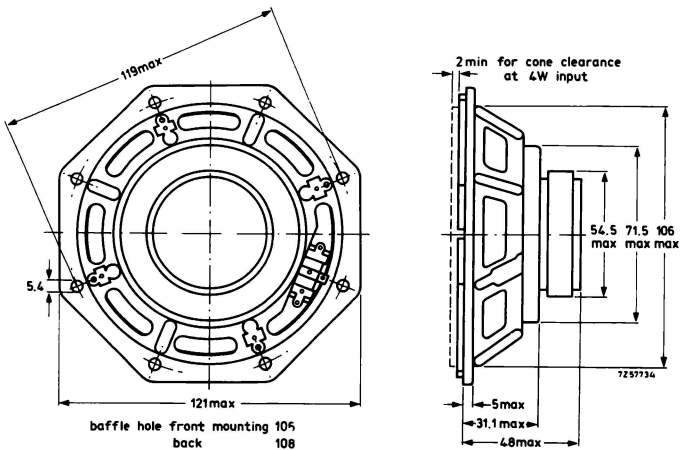

AD 1256/W

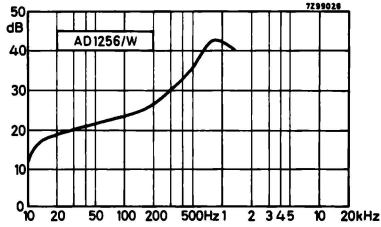
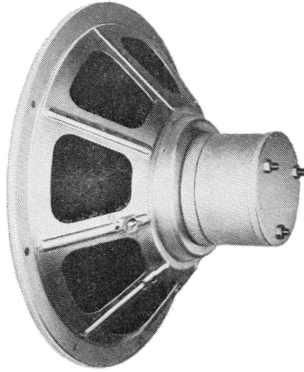

12" High Fidelity Woofer

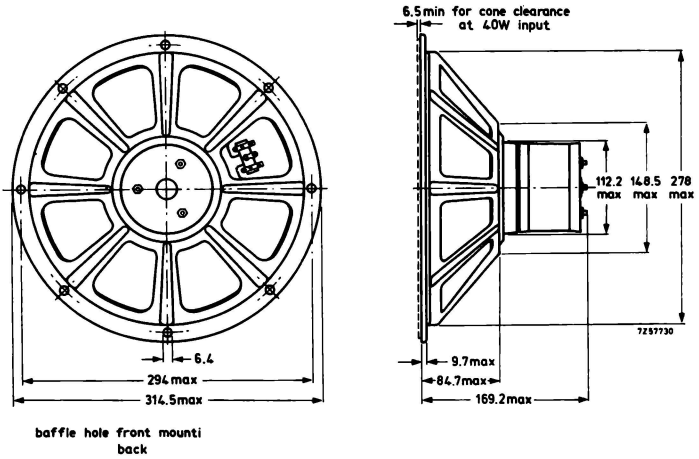

AD 1055/W

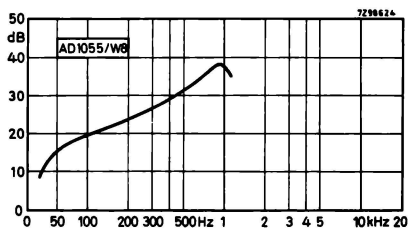
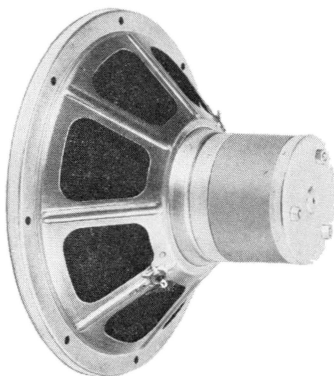

10" High Fidelity Woofer

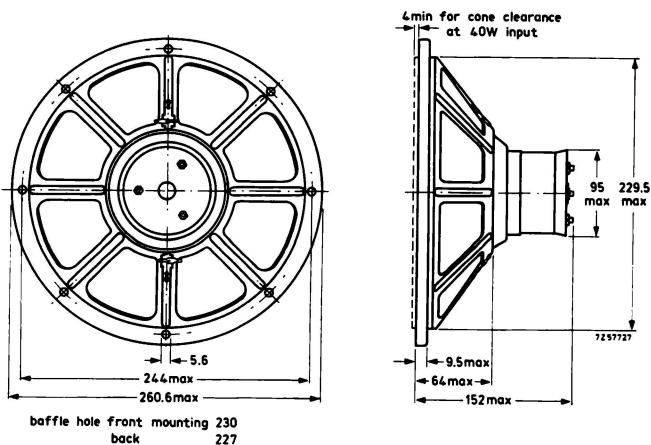

AD 8065/W

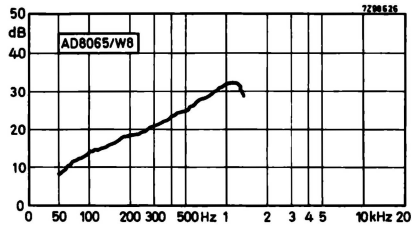
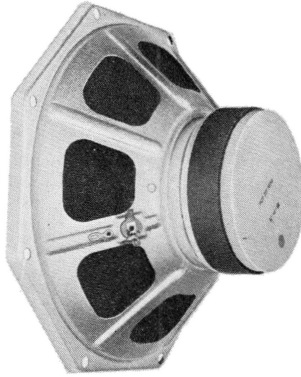

8" High Fidelity Woofer

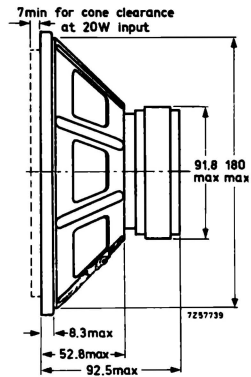
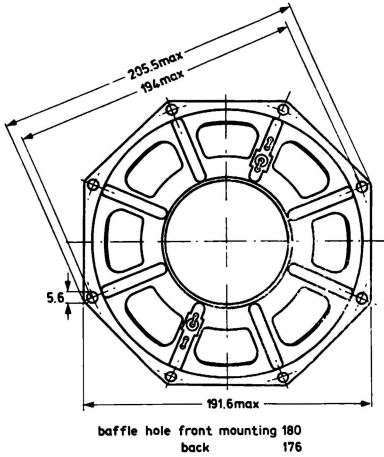

AD 7065/W

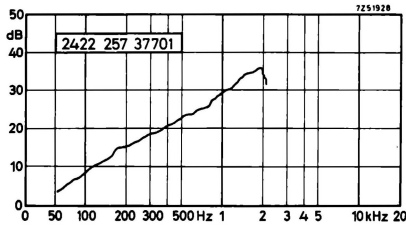
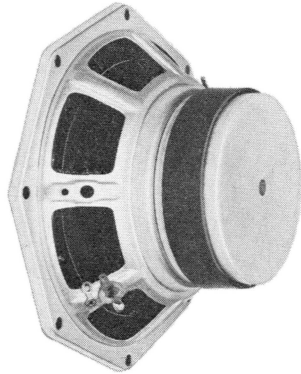

7" High Fidelity Woofer

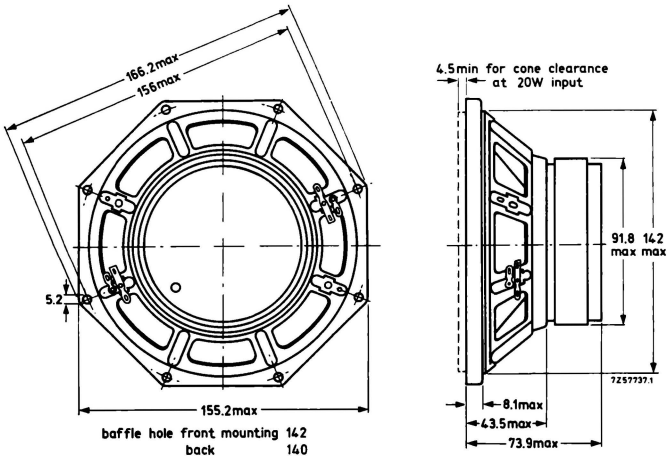

AD 5060/W

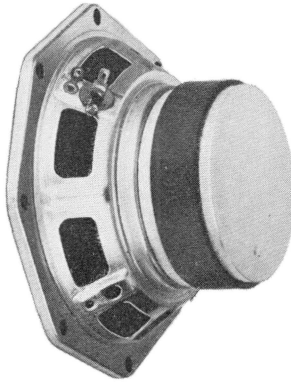

5" High Fidelity Woofer

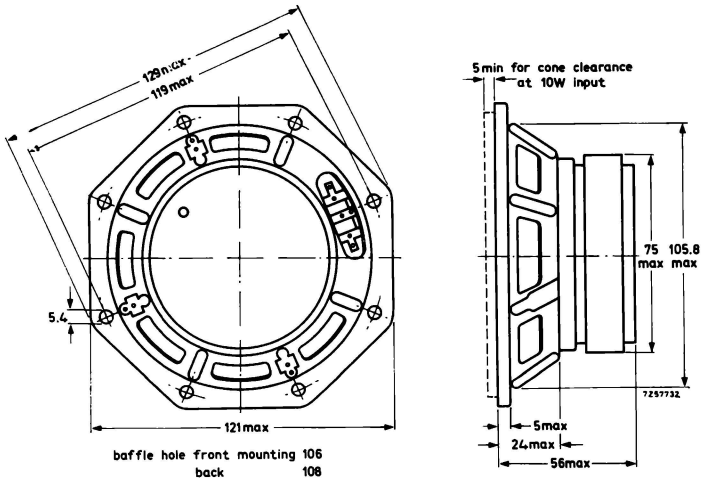

AD 2070/T

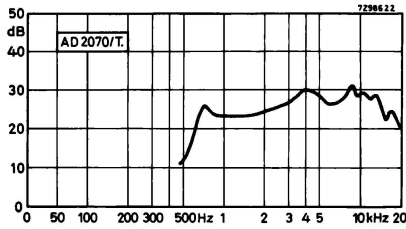
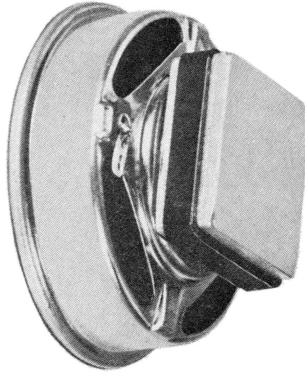

2" High Fidelity Tweeter

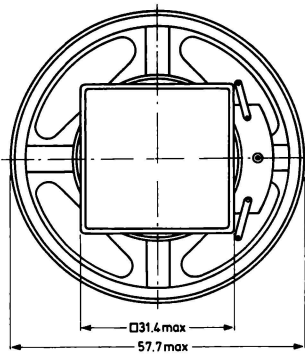

baffle hole front mounting 53

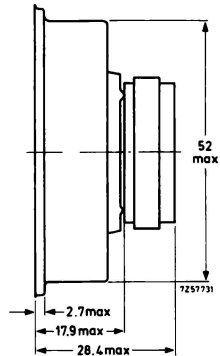

High Fidelity Loudspeakers for Two-way and Three-way Systems

Where a power level is quoted, this refers to the input power when the speaker is mounted in the recommended enclosure, otherwise the speaker would be permanently damaged.

AD 0160/T

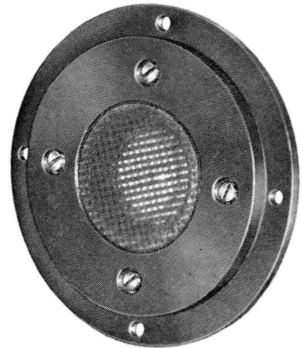
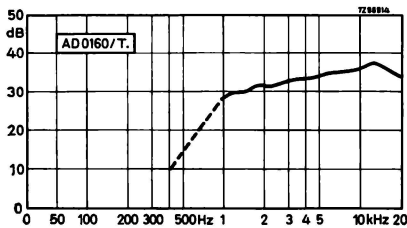

1" High Fidelity Dome Tweeter

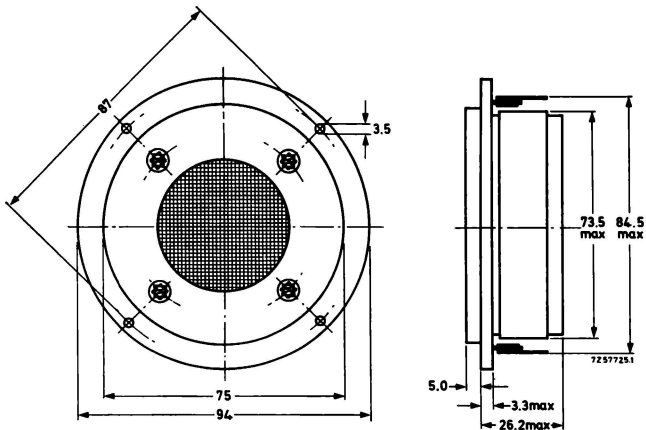

AD 1255/M

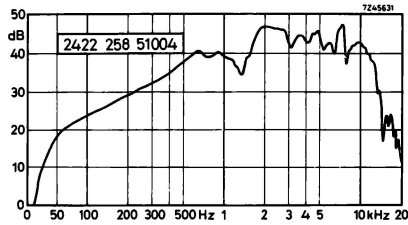
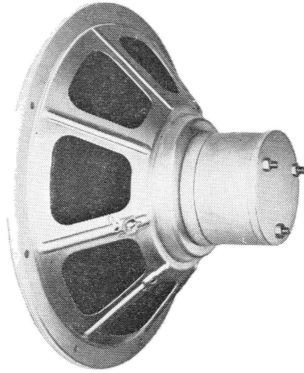

12" High Quality Loudspeaker

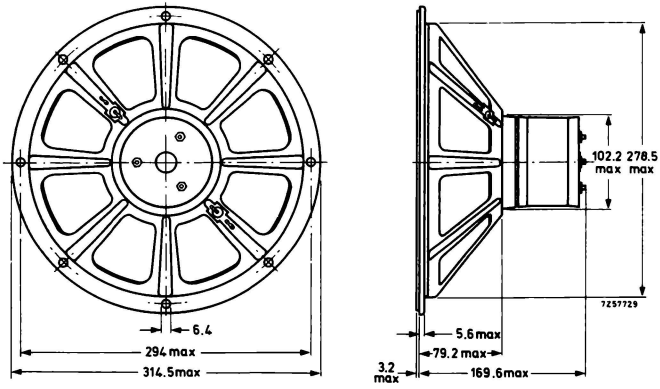

AD 1250/M

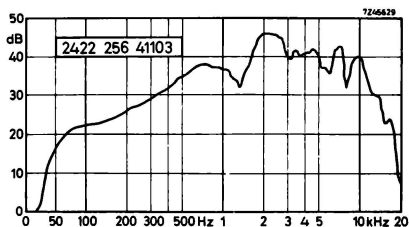
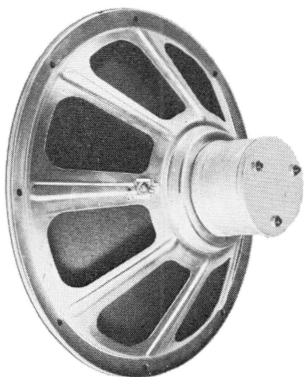

12" High Quality Loudspeaker

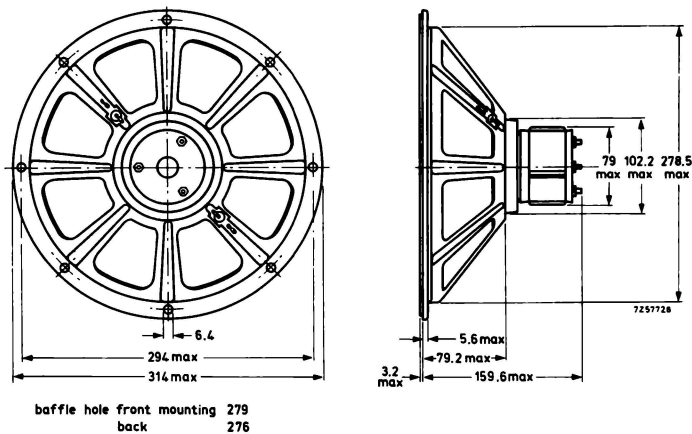

AD 1050/M

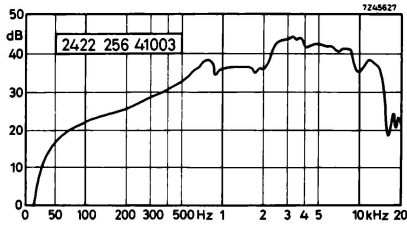
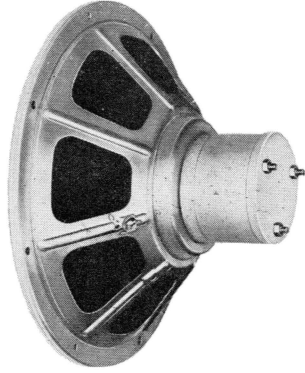

10'' High Quality Loudspeaker

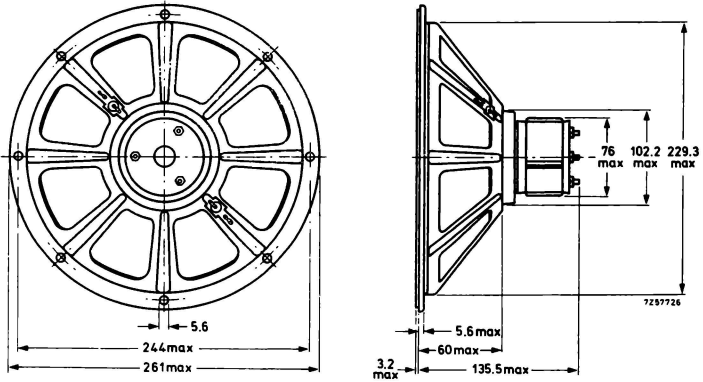

9710/M

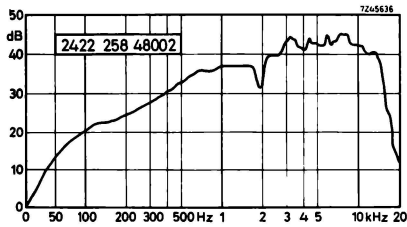
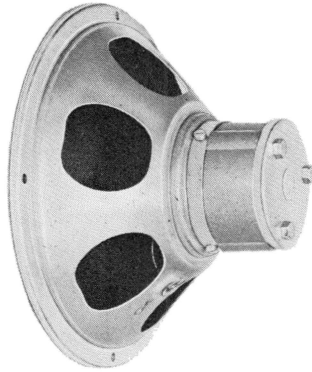

8 1/2" High Quality Loudspeaker

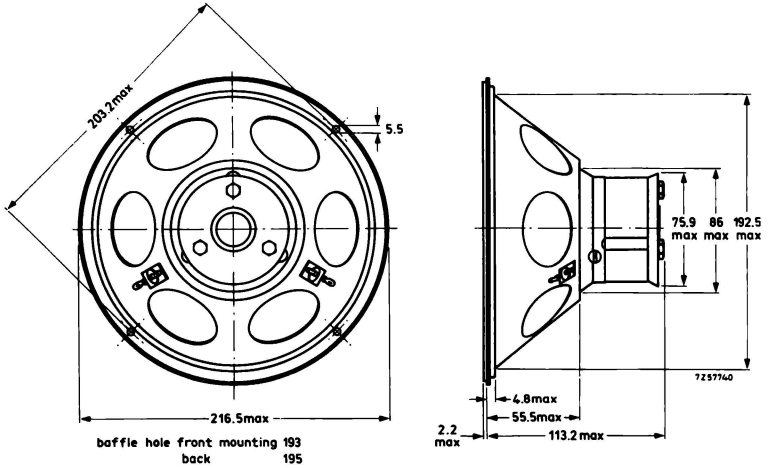

AD 8050/M

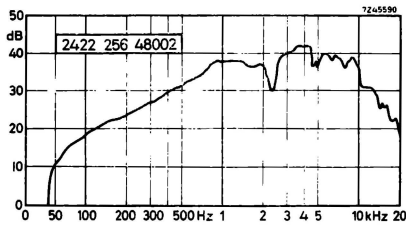
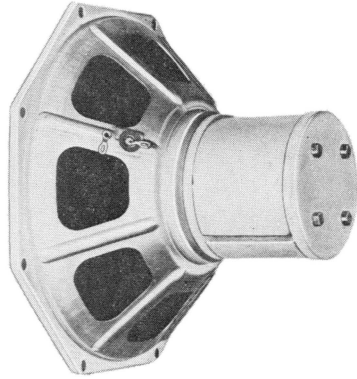

8" High Quality Loudspeaker

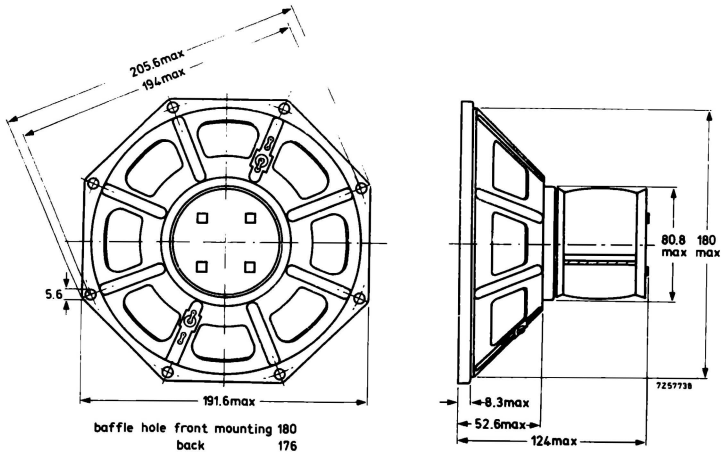

AD 7060/M

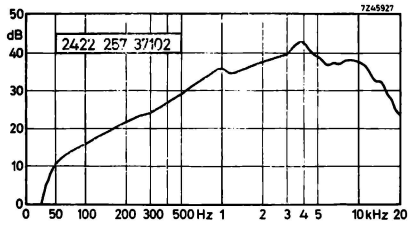
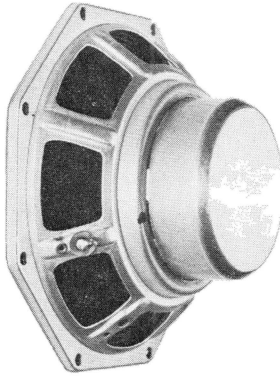

7" High Quality Loudspeaker

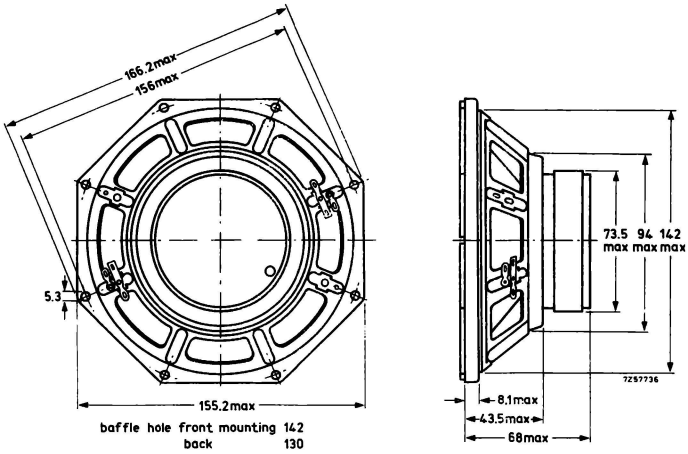

Appendix 2 - Speaker Dimensions and Response Curves

This Appendix gives the dimensions of the speakers recommended in this book. The response curves were measured with a constant voltage input in an anechoic chamber, without a baffle.

High Quality Loudspeakers for Simple Installations

AD 5060/M

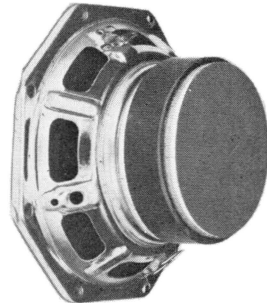
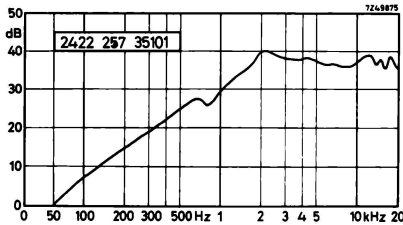

5" High Quality Loudspeaker

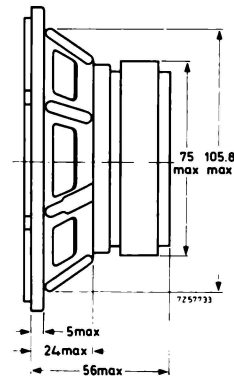
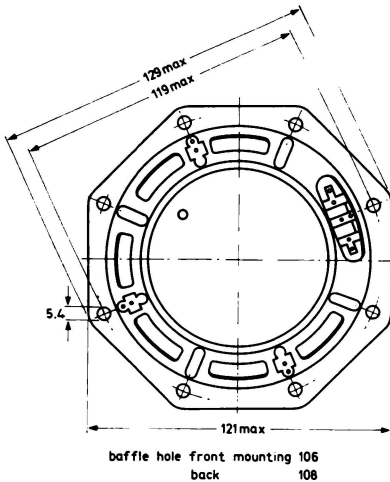

Table A.1. Winding Data for Cross-over Filter Coils using 1.2 mm diameter Enamelled Copper Wire.

inductance (mH)	no. of turns	coil former (see Fig. A.1)
0.175	95	A
0.25	115	A
0.35	130	A
0.5	150	A
0.6	160	A
1.0	205	A
1.2	220	A
1.5	240	A
2.1	275	A
3.0	385	B
3.2	390	B
6.4	515	C

Capacitors

Filter capacitors should ideally be paper dielectric types. But in view of the size of the larger values of capacitance, it is preferable to use bipolar electrolytic types. If some difficulty is experienced in obtaining such capacitors, it is possible to use two normal electrolytic capacitors back to back as shown in Fig. A.2. When two capacitors are connected in series it will be necessary to double the value of each capacitor to obtain the necessary overall value. If required, parallel, or series-parallel, combinations can be employed. Where two parallel capacitances are used, the value of the capacitance of each parallel path should be halved. Capacitors should have a working voltage of 100 V.

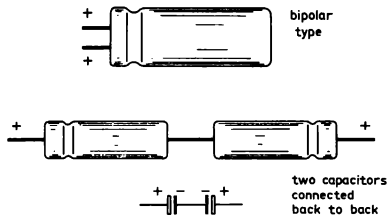

Fig. A.2. Showing how two electrolytic capacitors can be connected to produce the equivalent of a bipolar type.

Appendix 1 - Cross-over Filter Components

The values of the components needed to build the various cross-over filters were given on pages 29 to 52. The resistor values of $3\ \Omega$ and $10\ \Omega$ are not difficult to obtain, but the values of inductors and capacitors may cause some difficulty, particularly the inductors. This Appendix gives helpful details to enable constructors to wind their own coils and also how to obtain the required values of capacitance, if difficulty is experienced.

Inductors

For simplicity, air-cored inductors are specified here. These may be wound on simple bobbins having a basic diameter of 25 mm, using 1.2 mm diameter enamelled copper wire. The use of 18 SWG copper wire is permissible but, since it will result in coils of a slightly greater inductance, a reduction of about 1% in the recommended number of turns should be made.

Table A.1 gives the number of turns required to wind the coils. Three types of bobbins are used and details of these are given in Fig. A.1. The self-inductance of the coils can be determined from the formula:

$$L = \frac{N^2 \cdot a^2}{\pi \{(6a + 9b + 10c)\}} \text{ (mH)},$$

where N is the number of 100 turns, a is the radius of the average turn, b is the winding length and c is the depth of the winding (a , b and c in mm).

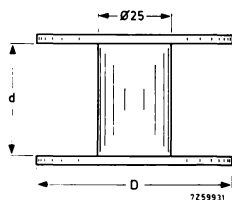

coil former	d (mm)	D (mm)
A	25	70
B	40	70
C	40	80

Fig. A.1. Details of coil formers for filter inductors.

Printed in The Netherlands

5BA01 ① 11-'70

9399 263 04601