

Circuit 2. Op amp based current mode driver.

This design uses a high performance audio op amp to provide the gain for a current feedback mode power amplifier and is the basis for the Amplifier Modules shown on page 1.

The op amp drives a low impedance load, and the rail currents of the op amp are first voltage translated by TR1 and TR4, then current inverted by the two Wilson current mirrors TR2 - 3 and TR5 - 6. This provides a differential current drive to the buffer stage TR8 - 11. Diodes D2 and D5 prevent saturation of the current mirrors. TR7 provides temperature compensated bias control.

The feedback is taken to the output of the op amp. The op amp cannot draw enough current from the current mirrors to provide the necessary voltage on the load resistance at its output terminal. By drawing current through the supply pins the voltage at the power amplifier output will rise to the point where current through the feedback resistance will create the required voltage at the output of the op amp.

The drive circuit can provide full output (150 Vp-p) at over 100 kHz while driving 12 pairs of devices. The maximum rail voltage is limited by the voltage ratings of the drive transistors. By changing the driver transistors for higher voltage types, rail voltages of +/- 100V can be used to drive the 200V MOSFET devices. If 300V transistors are used, then the circuit will be capable of driving the Profusion range of 250V MOSFETs

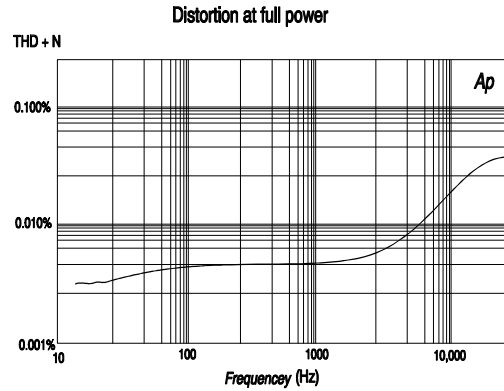

Circuit 2. Op amp based current mode driver.

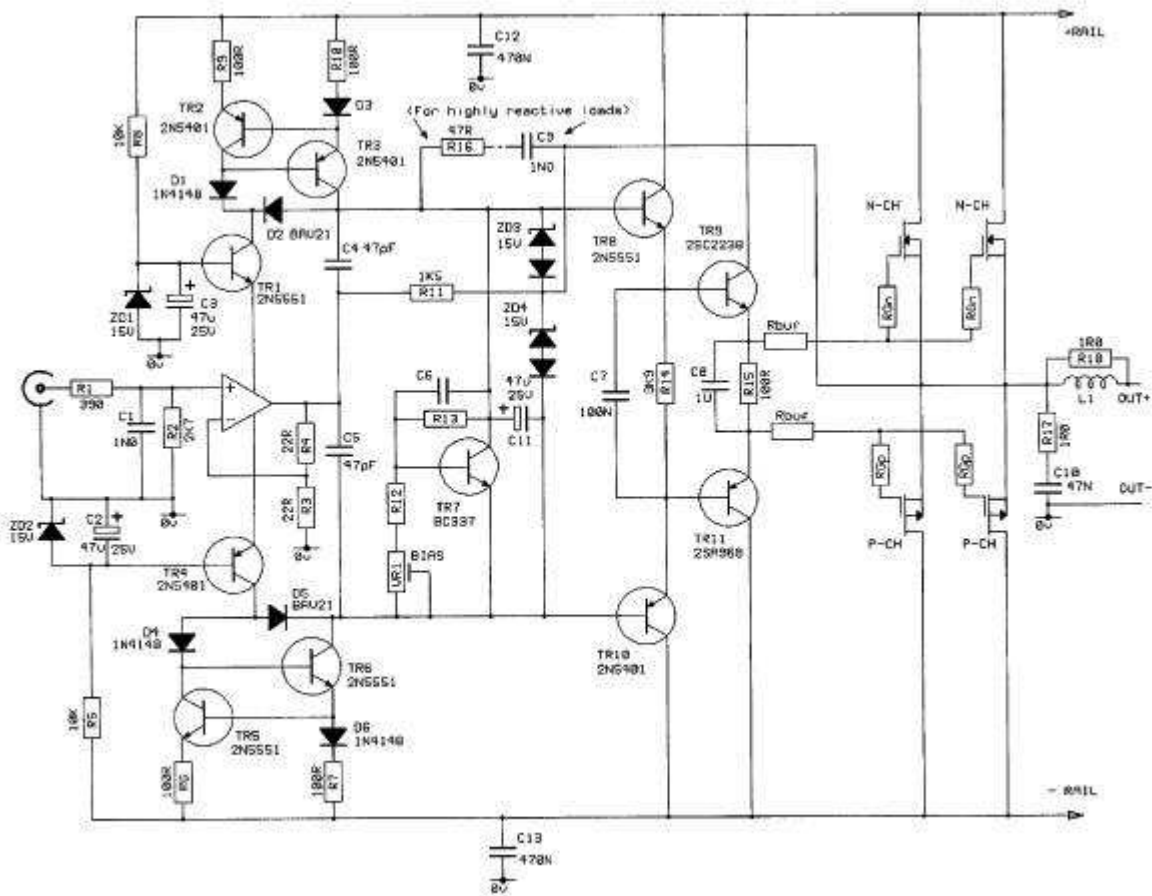

Most components are not particularly critical, however the following should be taken into consideration:

1. Use good quality transistors in the high voltage locations. Cheap devices often have poor gain, and can fail prematurely.
2. The bypass capacitors on the driver rails should be low ESR types. This includes the zener bypass capacitors
3. The Zoebel network resistor must be non inductive, i.e. a power film type. The capacitor should have a polypropylene dielectric, especially if high frequency signals at high amplitude are to be handled.
4. The amplifier cannot be more linear than its feedback network. Use good quality metal film resistors for R3,R4 and R11. R11 can dissipate significant amounts of power at full sinewave output. Several 0.6W 1% metal film resistors in parallel will provide adequate dissipation for most applications with good gain accuracy.
5. D2 and D5 see almost the full rail to rail voltage. These must be very fast and high voltage types to prevent breakdown. The recommended part BAV21 is inexpensive, and works well. Don't replace it with a 1N4148 unless the supply rails are less than +/- 50V.

Component substitution:

The circuit as shown is rated for +/- 80 volt rails. By substituting different drive transistors, the rails can be increased up to +/-100 volts for the 200V MOSFETs.

+/- 80v	+/- 100v
2N5401	MPSA 92
2N5551	MPSA 42
2SA1306/968	MJE 350
2SC3298/2238	MJE 340

The higher voltage devices have lower gain and speed, and the performance of the circuit will reduce slightly at high frequency. If driving a large number of MOSFETs at high voltage, it may be advisable to parallel two or more of the MJE devices to ensure reliability. Use a 22 ohm ballast resistor in series with the emitter of each device to ensure current sharing. Mount the drivers on a heatsink to keep the junction temperature as low as possible.

The gain can be varied by changing R11, but this should be limited to a range of 560 ohms to 2k2 to maintain stability. The gain can be further varied by adjusting the op amp gain via R4. The op amp gain can be increased to 10 before its bandwidth drops below that of the associated driver circuit.

Bias for the output stage is controlled by VR1.

Bias adjustment can be made by inserting an ammeter in one of the rails, or by monitoring the amplifier output at high frequencies with a sensitive distortion analyser. The bias can then be adjusted to remove the crossover blips on the distortion trace.

Muting

This circuit has a considerable turn on thump. This can be eliminated by conventional relay muting in the output line or by slugging the drive nodes before the emitter follower. C11 is replaced by two series connected 1000µF electrolytics, and the centre tap of these capacitors is connected via a 100 ohm resistor to a relay contact. The other relay contact is grounded. When the relay contacts are closed, the input to the drive circuitry is effectively shorted at audio frequencies. As this is a relatively high impedance node, the turn-on thump is greatly attenuated.

A second relay contact must short the input of the op amp to ground. This prevents the op amp pulling large currents in an attempt to drive the output, should a signal be applied to its input when the amplifier is muted.

The inductor in the output line isolates the amplifier from capacitive loads. The required inductance is small, <1µH, and an air cored coil made from 10 turns of 1.3 mm wire with an internal diameter of 5mm works well. The 1 ohm resistor reduces the Q factor of the inductor to prevent ringing on transients.

Power supply considerations.

The power supply should be capable of supplying the module with D.C. equivalent to 150% of the RMS output power.

The power supply capacitors should be at least 2,000µF per amp drawn from the supply rail. This will yield approx 1 volt p-p of ripple, which is a good compromise between cost and performance. For applications where the sound quality is of prime importance, the capacitance should be increased to 2 or 3 times this value.

The mains transformer should be sized according to expected usage. Hi-fi amplifiers use a transformer rated at approx 1.5 x the total output power (in VA). For a stage or P.A. amplifier the factor should be 2 - 2.5 times the output power.

Oversize power transformers will also enhance the sound quality.

The rectifier can be made from discrete diodes or a bridge rectifier. Remember that bridge output ratings are given at relatively low case temperatures, and should be rated accordingly. Leaded diodes dissipate much of their heat through their leads, and require large PCB lands to achieve their full ratings.