

THE WILLIAMSON AMPLIFIER OF 1947.

An account of D.T.N. Williamson's quality audio amplifier design as published in 1947: Background, development, and fortunes.

by P. R. Stinson.



Author's revised edition October 2015

THE WILLIAMSON AMPLIFIER OF 1947.

An account of D.T.N. Williamson's quality audio amplifier design
as published in 1947: Background, development, and fortunes.

by P. R. Stinson.

1. INTRODUCTION.
 2. AMPLIFIER TECHNOLOGY. 1908-1939.
 3. D.T.N. WILLIAMSON.
 4. THE QUALITY AMPLIFIER. 1944-5.
 5. THE POSTWAR AUDIO SCENE. 1945-7.
 6. EARLY REACTION TO THE QUALITY AMPLIFIER. 1947-8.
 7. THE PROGRESS OF THE WILLIAMSON. 1948-51.
 8. THE WILLIAMSON IN AMERICA. 1948-51.
 9. THE ULTRALINEAR STAGE. 1951.
 10. CONCLUSIONS.
- Postscripts.

Author's Preface.

I recognise that this paper is a very selective ramble through the history of audio, and an incomplete account of the contribution of D.T.N. Williamson, but I discovered that trying to describe the Williamson amplifier out of context was very difficult, and I suspect, somewhat less interesting than the story which resulted. The quest for high fidelity sound reproduction is a good story and perhaps this paper will encourage more interest in the subject. I hope it will also encourage the rescue and restoration of the surviving Williamson amplifiers.

P.R.S. February, 1991. Sydney, Australia
Plus some later refinements. October 2015.

INTRODUCTION.

In April-May 1947, the British monthly electronics periodical *WIRELESS WORLD* published articles entitled "Design For A High Quality Amplifier" from contributor D.T.N. Williamson. The articles gave the rationale behind the design, the circuit and the details required by constructors who might wish to build the amplifier.

The article was one of an occasional series of "quality" amplifier designs which had been a popular feature of the magazine for many years. Radio and electronic construction was a very popular hobby activity of the time and *WIRELESS WORLD* as widely known as a source of good quality electronic projects.

Williamson's contribution derived originally from a personal hobby project which had begun in 1944, with no thoughts of wider application. After publication in 1947, however, his design achieved an astonishing degree of recognition, far beyond the realms of hobby projects. Enthusiasts constructed the amplifier in large numbers, laboratories experimented with it, commercial amplifier makers adopted it for their flagship models and "The Williamson" became a major topic for discussion in the popular electronic and radio magazines. By 1951 it was in wide use in Britain, France, Scandinavia, North America, Australia, New Zealand, South Africa, and was regarded as the standard by which all audio amplifiers should be judged. No other name was so *universally* accepted at that time as being synonymous with high quality sound reproduction in the home. It would continue to hold this special reputation for many years though after 1951 its supremacy would be challenged by some other developments. The challengers never actually displaced the Williamson design on the basis of sound quality but rather in areas of maximum power delivery and efficiency.

The Williamson design played an important role in setting the standards for present day high quality sound reproduction, and yet today one finds little mention of this once famous design. Many text books on audio amplifier design throughout the 1950's and even later gave it special consideration and in total, some tens of thousands of examples must surely have been home-built or purchased, an enormous number in the marketplace of the time.

D.T.N. Williamson was also the designer of arguably one of the best pickups of pre-stereo days (the Ferranti Ribbon, 1953) and played a key role, with his friend Peter Walker, in the development of the QUAD Electrostatic Loudspeaker of 1956, the most accurate speaker of its day and still a standard today. Regrettably for audio, his talents were subsequently concentrated on other technologies in which he achieved major distinctions.

Our story covers some important events in audio up to the mid-1960's. To start, we will review the early development of audio amplifier technology. A full treatment would require several books, so only a very limited review of the evolution of some aspects of amplifier progress is possible, to provide a background to the features of the Williamson design, and to the rise of the concept of quality audio in the home. American readers may need to think "tube" wherever they read "valve".

2. AMPLIFIER TECHNOLOGY 1908-1939.

When DeForest developed his triode "Audion" valve in 1908, it was in the role of an improved "detector" of radio frequencies, and it was some years before the potential of the Audion as a general purpose amplifier of alternating currents was fully grasped. It was the Telephone Engineers who first began to methodically exploit the triode valve, for long distance repeater amplifiers, from about 1914.

During the First World War, valve and amplifier developments were confined to military and naval purposes and some technological progress was made, but with most of the emphasis on wireless telegraphy and very basic speech telephony. Valves would not become widely available to the public and amateur experimenters until about 1919. Only the most rudimentary diode and triode types existed. Wide band audio was not even a concept, let alone an objective.

Early Broadcasting technology. 1920-5.

When broadcasting began in the early 1920's, the technology employed was a mixture of telephone engineering in the primitive "studio", and adaptations of Wireless Telephony/Telegraphy engineering for the transmitter. The early studios were equipped largely by telephone corporations such as Western Electric, who were thus called upon to develop purpose designed "low frequency" amplifiers for broadcast studios, using the simple triode valves of the time. Early systems rarely covered more than speech frequencies generated by the (very primitive) carbon microphones then in use, and any programme monitoring required was by simple high impedance headphones, thus the audio frequency amplifier requirements were minimal at this early stage.

Domestic "audio", where it existed up to the mid 1920's mostly comprised the wind-up gramophone and perhaps a battery operated wireless set, the latter tricky to operate and tiring to listen to through uncomfortable headphones. A more advanced set might have a stage or two of the most elementary triode amplification, to boost reception of faint signals or feed a primitive speaker so that the family could listen, but the battery drain of elaborate multi-stage sets was a severe drawback, particularly if they still used the older type of valve with bright filaments.

The "loudspeakers" in use at the time could not reproduce a wide band of frequencies, nor could they accept more than feeble currents. The early speakers were almost all moving iron types, of reed, balanced armature or the telephone receiver (plus megaphone horn) type, and many were little more than poor narrow-band resonators. *WIRELESS WORLD* published frequency response curves for some of these primitive speaker types in the 1920's - the "curve" often exhibits a terrific peak at some upper speech frequency, say 3 kHz (would have been useful in headphones perhaps). Anything more than the slightest degree of amplification usually triggered gross distortion, thus an audio amplifier stage was of limited usefulness.

The Moving Coil Loudspeaker. 1925.

By 1925 audio amplification in the laboratories of Western Electric had certainly evolved sufficiently to permit development of a practical system of electrical recording of sound on disc, covering a frequency range of about 6 octaves. The emergence of the Moving Coil Loudspeaker in practical form in the same year, from its developers at General Electric was an important and liberating event which made reasonably wide band sound reproduction a possible objective for the first time. Exploiting it, however, required better audio frequency amplifiers capable of delivering power measured in watts rather than milliwatts. These were developed at the same time.

Distribution of mains electricity to homes was far from universal in 1925 and there were different systems in use (DC as well as AC), with many different operating voltages, but the availability of some form of mains supply would extend rapidly thereafter. With this service, amplification of radio signal and record through a loud speaker in the home became a practical option and the set makers responded by creating the "Radiogram" from about 1927 onwards. If the new type of speaker was used, such sets would incorporate a simple triode valve power output stage to provide the current for it. The early moving coil speakers also needed mains power to energise their electromagnets. The sound quality produced by these first all-electric sets often left much to be desired, but improvement was rapid.

Mains energised amplification and the moving coil speaker were also essential for Sound Motion Pictures (1927) and the demand for consistent and reliable amplifiers of decent quality for this purpose led to improved circuits and valves, so that by the end of the 1920's triode amplifiers using "push-pull" configuration for the output stage were becoming common enough where any serious purpose was intended. The distortion produced by a single triode was substantial, but almost entirely of second harmonic (least objectionable) kind, and push-pull operation cancelled much of it out. The idea of balanced push-pull working for output valves, to cancel much distortion and assist power delivery, had been put forward as early as 1915, but was of limited value until the advent of improved loudspeakers.

In the broadcasting studio, the new electrically recorded discs, electric reproducing pickups, improving microphones and amplifiers transformed the quality of broadcast recorded music. Until 1925 the source had been an acoustic gramophone playing to a carbon microphone, a very low-fi combination indeed.

"High Fidelity" Radio Receivers. 1934.

By 1934 improvements in radio detection and tuning circuits were substantial, so that reliable and fair quality reception was easily achievable by large populations around major cities and towns. Much improved engineering and transmitters provided a radiated signal of wider audio frequency bandwidth, to which the older receivers and amplifiers were ill matched, and new generations of receiving equipment had replaced them.

In the U.S.A. around 1931-2, there had been much enthusiasm for the "Loftin-White" technique of direct stage coupling (no capacitor or transformer) to help maintain wide frequency response, but the tricky juggling of circuit voltages required, difficulties with hum and the dubious reliability of components proved too troublesome outside the laboratory, and by 1934, the craze had passed.

In this year the more ambitious receivers were promoted with claims of superior quality and the description "High Fidelity" was much in vogue, then defined as covering the audio frequencies 60 to possibly 7500 Hz, some seven octaves, for daytime reception of those stations radiating the better quality transmissions. For reproduction from records, electric pickups had also improved, but the upper useful limit was more like 5000 Hz, hardly what we would think of as high fidelity today. The emergence of the "tone control", capable of drastically cutting even this modest treble response to reduce disc record surface scratch and ameliorate radio interference at night, was inevitable at the time, but unhelpful in the pursuit of fidelity.

Quality Push-Pull. 1934.

The concept of sound fidelity as an objective was becoming accepted, and in May 1934 *WIRELESS WORLD* published a design for a "Quality Push Pull" audio amplifier from W. T. Cocking. The article was headed "Quality Amplification" and the discussion was comprehensive: Pentode vs triode output, transformer vs RC (Resistance-Capacitance) stage coupling, speaker impedance, power delivery requirements and the various types of distortion, thus most aspects of amplifier performance were well enough understood by that date. The required performance was defined as 25 to 10,000 Hz within a 5dB window, including the output transformer, and less than 5% total distortion, an advanced specification for 1934.

The design used two stages, both push-pull, R-C coupling, with triodes for output (Marconi-Osram PX4s). An additional pre-stage for gramophone pickup was also described. It produced 4 watts of audio for about 3-4% distortion or 6 watts at the 5% limit. This kind of performance was considered all that could possibly be needed at the time (and for the decade that followed). While perhaps not the first design for domestic use where audio quality was a serious consideration, it was certainly one of the earliest to be based on a serious discussion of the parameters. In the mid 1930's very few loudspeakers could do justice to such an amplifier, the Voigt Domestic Corner Horn speaker being a notable exception.

Negative Feedback. 1931-6.

Meanwhile, at Bell Laboratories in the U.S.A. from 1930, researchers developing multi-channel narrow band amplifiers for telephone systems had shown that amplifier distortion could be reduced dramatically by channelling an inverted sample of the output signal back to the input path. This inverse or negative feedback forms a control mechanism which essentially compares the output with the input and permits the amplifier to track and, to some extent, reduce its own tendency to add harmonics to the signal being amplified. In a high gain amplifier even a very

small sample will have a dramatic effect, considerably reducing its sensitivity but also greatly improving its accuracy. Using this inverse feedback, the resulting drastic reduction in crosstalk between frequency channels was of major benefit to telephone engineering. This new technique emerged from the laboratories in 1934.

Use of this feedback technique in domestic audio amplifiers made it possible for set makers to consider the more recent pentode valve type in output stages, gaining much power efficiency while substantially reducing the otherwise harsh distortions normally associated with this valve. The cost savings were important in the depressed economic circumstances, but lack of appreciation of the limitations of feedback was common and the bad results obtained by some constructors using pentodes and feedback, without the necessary expertise, led to the approach attracting a unfortunate reputation which would persist in some quarters for many years.

In November 1936 *WIRELESS WORLD* began articles describing an AC/DC amplifier employing pentodes with negative feedback, with accompanying articles about feedback theory and its applications. While claiming reasonable quality the real objective of this new design was to obtain useful power from output stages operating from DC mains, with only 200 volts or so of high tension supply to work with. From such a low voltage 4 watts could be obtained readily from push pull pentodes but feedback was necessary to contain distortion. The format was push-pull for the two stages, with feedback around the output stage only. These articles helped foster popular understanding and interest in feedback. Importantly however, there was no suggestion at the time that any pentode+feedback approach might supersede the earlier 1934 quality design, nor that any approach other than plain push-pull triodes was appropriate for quality purposes if AC mains power was available.

Distractions and diversions. 1934-7.

Experiments in advanced audio technology had been going on in laboratories since 1930 - long playing formats at RCA-Victor, stereo at EMI, wide band recordings and stereo at Bell Labs - but nothing practical had reached the consumer. Some of these experiments might have been carried through to products had it not been for the upsurge of interest and publicity for the new marvel, experimental television, from 1934. Short wave reception (necessarily low-fi) also had some prominence in the mid 1930's and set makers included elaborate shortwave sections in their products. There is no doubt that these new enthusiasms captured the interest of the engineers and the public alike, and the pursuit of audio realism all but stalled. Some of the indifference to E.H. Armstrong's 1935 proposals for high quality broadcasting using Frequency Modulation may have been due to this cause.

Beam Power Tetrodes and the KT66. 1936-9.

In 1936 the "Beam Power tetrode" valve had appeared in the U.S.A., (RCA's 6L6). Of similar high power efficiency to the power pentode, the unique construction of this new type generally produced much lower levels of dissonant (odd numbered)

harmonic distortion than common pentodes. This type of valve immediately became the dominant type in commercial audio power stages.

In 1937 Marconi-Osram Valve Coy (a subsidiary of G.E.C. in Britain) introduced their own range of beam tetrodes, one of which was the KT66, a valve which would have a long career and almost become the characteristic valve of high fidelity equipment well into the 1960's. The new valve could also be connected into the circuit to operate as a triode if required and was then similar in performance to Marconi-Osram's previous power triode (the PX25) but having more modern construction and indirect cathode heating. Few, if any, users would have employed it in triode mode in those days, the higher gain of straight tetrode operation was the predominant form of usage for the "Beam" valve.

Each year Marconi-Osram published a small "Book of Circuits" and trade pamphlets to make suitable application information available. The 1937-8 booklets show circuits for the KT66 in push-pull tetrode with feedback configurations, but no quality claims were made as most of these circuits were intended for P.A. (Public Address) applications, a major industry of the time.

Output Transformer Theory and Practice 1938-40.

A British manufacturer of interest in the late 1930's was Norman Partridge, who would become well known for the excellence of the transformers which he manufactured. From about 1936, his firm offered several circuits specifying push-pull triodes but without feedback, employing (not surprisingly) transformer coupling between stages and sometimes all stages in push-pull configuration. Though mainly intended for P.A. work, the careful design and good quality of the components and transformers ensured that performance was good for their time.

Coming from a transformer specialist, Partridge's circuits naturally included the output transformer as part of the overall design process, but this approach was uncommon. Many general purpose designs left it to the user to choose the output transformer and speaker either separately or as a package, and the loudspeaker makers supplied or recommended a range of transformers (supposedly) suiting the popular output valve configurations of the day. Matching the amplifier to the speaker system was thus a fairly chancy process.

For tetrode and pentode output stages it was not adequately appreciated at the time just how complex was the interaction between the output valves, the output transformer and the loudspeaker motive system, the vagaries of which were reflected back into the amplifier. In time it would be shown that high performance amplifiers could not be designed consistently without detailed consideration of the dynamics of the load to be driven, a problem which still continues today.

In 1938 Fritz Langford-Smith wrote a detailed paper for the World Radio Conference of that year which examined the effects of the loudspeaker's low frequency resonance on amplifier performance and showed that the output of the speaker at this frequency commonly represented as much as 50% distortion,

(harmonics of lower frequencies) with conventional pentode and tetrode output stages. With typical speaker resonances around 70-90 Hz this distortion was all too audible, combining with typical cabinet resonances to produce a window-rattling "one-note" bass. This distortion, resulting from the absence of electrical damping of the speaker movement could only be effectively corrected by proper application of feedback, although Langford-Smith emphasised the importance of the damping system of the loudspeaker itself as well as that provided by the amplifier.

It was also recognised that it would be desirable to include the output transformer in the feedback loop from the secondary winding, but this was very seldom attempted. Transformers of sufficient quality to avoid severe phase shifts at the frequency extremes (resulting, in feedback circuits, in the amplifier becoming unstable i.e inclined to oscillate furiously at a single frequency rather than amplify broadband), were physically huge and too expensive for commercial set-makers. In 1939 an extensive series of articles on transformer theory and practice appeared in *WIRELESS WORLD* contributed by Partridge, which together with Langford-Smith's data (also reprinted by W.W) would have provided a much improved general appreciation of some important quality considerations.

Amplifier trends in the U.S.A. 1937-9.

In the U.S.A. there was great enthusiasm for very elaborate radio receivers featuring many facilities for reception on many wavebands. Powerful audio sections were often included, contrast expansion and noise reduction circuits, push button tuning and even cordless remote control appeared in the grander models.

As in Britain, straight audio amplifiers are to be found only in the P.A. and hobby fields. The hobby magazines such as *RADIOCRAFT* reflected the delight in features and complexity with a fearless approach to new circuits and ideas. In general the major focus tends to be on extensive radio reception ability, rather than on audio, and seldom does one find detailed evaluation of distortion problems in audio stages or transformers.

In audio output stages The RCA 6L6 beam tetrode in single-ended or push-pull arrangements was the most common configuration in commercial and hobby designs. Though this valve produced very high levels of second harmonic, this could be almost entirely cancelled by push-pull working, leaving only a low 2% of mainly third harmonic distortion, which could be further reduced by feedback. Use of modest levels of feedback was quite customary and in such configurations the 6L6 presumably gave good results for the time. Nevertheless, triode vs tetrode/pentode arguments are very much in evidence in the literature.

It is probable that at least some of the tetrode+feedback designs, though primitive, sounded cleaner than simple triode amplifiers, particularly where the latter were underpowered and likely to be operating into overload. Depending on the speakers used, the residual odd harmonic distortions of the tetrode types may have been obvious in some setups and not in others. Multi-speaker or other wide range speaker systems did exist but were rare in domestic systems, so good or bad results

were possible from both approaches. These differing experiences may account for the strong prejudices for both systems which become prevalent from this period. Designers such as the prolific A.C. Shaney, of AMPLIFIER CORP. of AMERICA, who contributed many sophisticated designs to *RADIOCRAFT*, was one of those who believed the triode output stage was outmoded, but others rejected the tetrode+feedback amplifiers with equal vehemence.

Amplifier Technology 1939.

By the outbreak of war in late 1939, the most common output stage for audio amplifiers comprised the beam tetrode valve, very often the 6V6 or 6L6, a single valve in the smaller sets, push-pull pairs in the larger. Some, but not all, of the more ambitious designs used a very small amount of feedback applied over one or two stages, but seldom if ever included the output transformer in the feedback scheme. This latter component was often of meagre specification and the cause of significant distortion outside the mid-frequency range.

Quite good amplifiers using push-pull beam tetrode output were certainly possible in the laboratory but only with the scientific application of feedback and top quality transformers. At the domestic level, without these preconditions, results were often suspect.

There remained a strong prejudice, where quality was an issue, for the plain and reliable approach of push-pull triodes, often the RCA 45 or 2A3, in simple class A operation, no feedback. Feedback was not considered necessary if the output stage utilised push-pull triodes, and was never suggested.

With the programme sources available, 5% harmonic distortion was considered innocuous and 2% more or less undetectable, though some workers were careful to distinguish between odd and even orders of harmonics and the need for low levels of 5th and higher harmonics was generally accepted. We should also bear in mind that distortion measurement procedures in those days were laborious and the required equipment uncommon, thus only simple tests could be undertaken. More searching tests such as intermodulation distortion measurement would not be common for almost another 10 years.

Sound reproduction in the home was typically mediocre, with uneven and undamped bass, limited highs and a general muddiness, and if the treble control was advanced a distressingly shrill quality around 3 kHz was common if the set used tetrode or pentode output, made worse by speakers which commonly had peaks around this frequency. Few complained, most users simply cut the treble response until they achieved a tolerable "mellow" quality (meaning dull). There was, however, a small band of enthusiasts for recorded and broadcast music who were unsatisfied with this state of affairs.

Some Audio Amplifiers 1930-39.



1930. A robustly built early audio amplifier by EMMCO, Australia.
Push pull triode output with interstage transformer drive.
The output is at high impedance requiring a loudspeaker with its own
transformer. 4-5 watts.

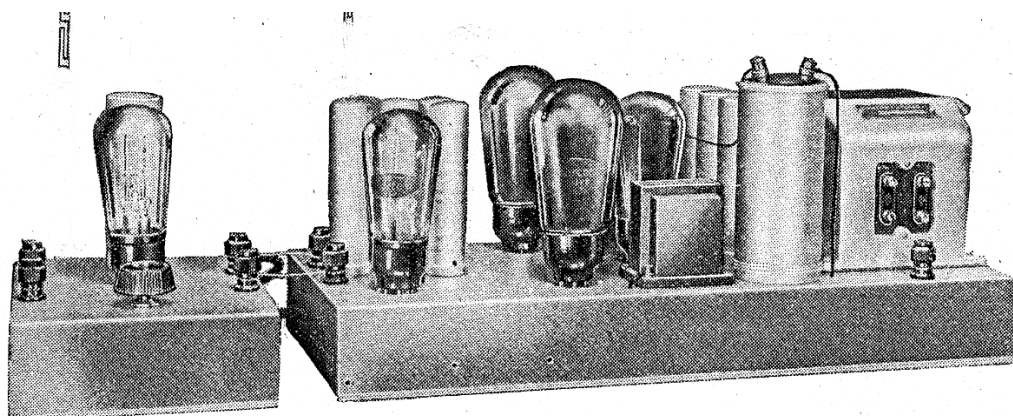

1934. The "Wireless World Quality Push Pull Amplifier"
Push pull configuration main amplifier with driver pre-stage.
Triode output, RC coupling, no feedback, 5-7 watts.

Some Audio Amplifiers 1930-39.

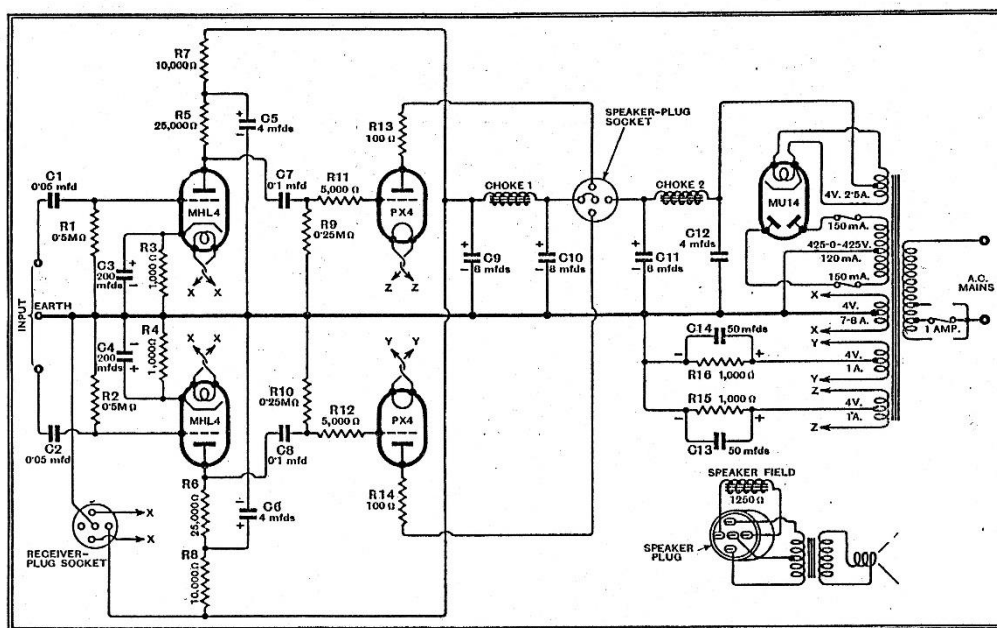

1934. The circuit for the *Wireless World* Quality Push Pull Amplifier. An additional pre-stage to provide the push pull drive was also described. Output transformer to be chosen by the user, according to the loudspeaker to be used.

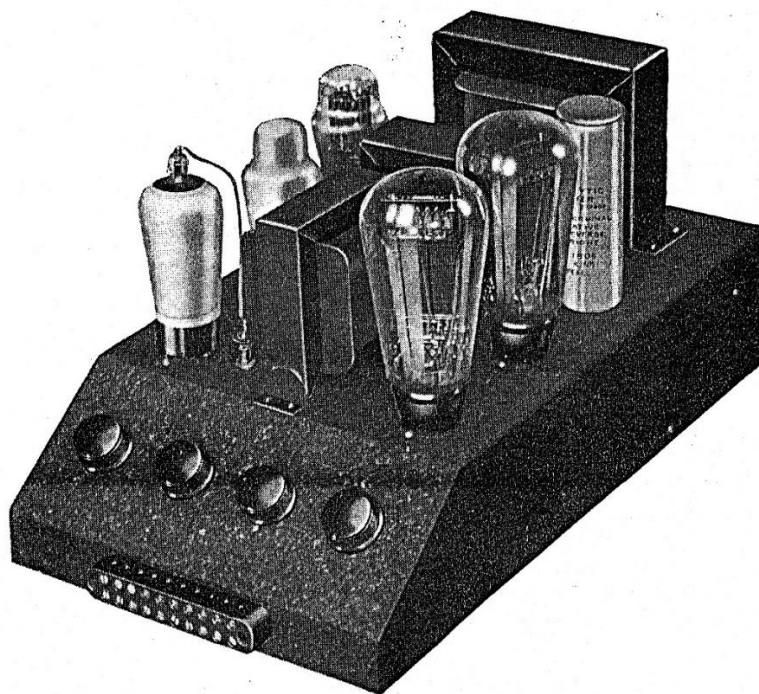

1938. A 12 watt amplifier by Partridge Transformers Ltd, England. Push pull triode output, transformer coupled, no feedback. A similar "Quality" unit was also available with an all triode circuit and higher grade transformers. Output transformer integral with the design.

3. D.T.N. WILLIAMSON:

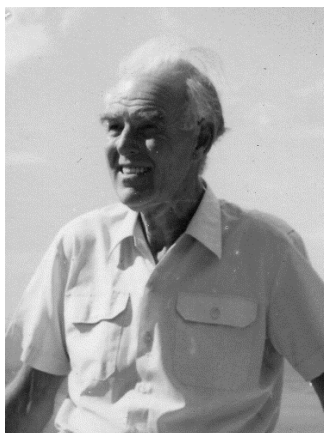

D.T.N.W.
(c.1990)

With the onset of war, European domestic audio development was curtailed of course, but laboratories continued work in some areas since quality amplification and recording had many wartime applications. An example was the Applications Laboratory of Marconi-Osram, whose job was to develop practical circuits using M-O's valve line, and assist users in any way which would encourage their use of M-O valves. The laboratory was run by the genial G. R. Woodville, and in April 1944, a young man D. T. N. Williamson joined the team.

David Theodore Nelson Williamson was born in Edinburgh in 1923. From about age 10, with the encouragement of his father, Theo became an enthusiastic constructor of radio kits, to designs published by the monthly periodical *POPULAR WIRELESS*, but it was an attempt at conversion of an old acoustic gramophone to electrical reproduction in 1936-7 which, due to the mediocrity of the result, intensified interest in seeking better quality sound reproduction. From this time Theo was strongly influenced by the enthusiasm of family friend Peter Stowell, who was an outstanding Electrical Engineer and a keen electronics experimenter, and through this acquaintance, Theo became a regular reader of *WIRELESS WORLD*. Between the years 1937 and 1942 he embarked on more and more advanced audio projects, building MW and SW receivers and a disc recording machine. Some of the early projects, undertaken during his school years, were well enough executed to win school prizes, a B.T.H. gramophone pickup and a multimeter were won.

A Feedback Amplifier. 1939.

All this practical work, absorption of much theory from magazines and library books, plus the guidance of an imaginative mentor, gave the young Williamson a considerable electronics expertise and confidence. Local mains supply being 230 volts DC, the type of AC/DC feedback amplifier described in *WIRELESS WORLD* back in 1936 seemed to be an economical proposition, particularly since another

new beam tetrode, the KT33C, had lately become available which in a push-pull pair could yield about 12 watts from a mere 200 volts high tension.

In 1939 Williamson constructed an amplifier of this type, 3 stages with output by push-pull KT33C tetrodes, preceded by L63 triode phase-splitter and L63 first stage, using a good make of output transformer and then experimenting methodically with feedback. A relatively small proportion of the output voltage was tapped off at the output transformer secondary and directed back to an early stage in such a way as to oppose the input signal. Experiments showed that the feedback sample could be set to a level where the sensitivity and distortion was reduced by a factor of about 10 times or in electrical terms 20dB. Overall feedback of this degree, and inclusion of the output transformer in the loop was quite unknown in domestic amplifiers of the time. These features would not be common until the 1950's.

The result; a 3 stage push-pull tetrode+feedback amplifier with advanced use of feedback. By comparison with the distortion performance of contemporary triode (no feedback) jobs of the 10-12 watt class, the amplifier gave good results. A re-coned 12 inch Baker speaker (of the wide-range type which used a curvilinear cone with aluminium dome apex) in a massive baffle cobbled out of a disused table-top was employed for listening, together with the B.T.H. pickup. A great deal of important experience was gained from the work on this experimental amplifier. How we would judge it today is an interesting question.

Also in 1939 Williamson had commenced university studies in Electrical Engineering. At that time such a degree involved study over a broader range of engineering knowledge than is typical today. Though specialising in the Communications options in his final year, in electronic matters Williamson learned little that he did not already know.

Contrast Expansion. 1940.

Interest in improving reproduction from records also led to some Williamson work on contrast (dynamic range) expansion from around 1938. Dynamic range expansion was a topic which had been hotly debated on both sides of the Atlantic since about 1935 and *WIRELESS WORLD* had published several articles on the subject, the motivation for which was the extraction of more lifelike dynamics from 78 RPM records. Theo experimented with this idea on and off between 1939 and 1943 and wrote some letters to *WIRELESS WORLD* commenting on the discussions there. He pointed out the necessity for differing attack and decay times in expander operation, which was by no means obvious to most of the contributors on the subject at the time. These letters, some of which were published in 1943, were of singular clarity and economy, a characteristic of all his writing. The outcome was *WIRELESS WORLD's* editor requesting Williamson to submit an article on the subject, to which he responded by providing a complete design for a contrast expander which was published in September 1943.

In 1943, in the middle of the War, Williamson was promptly assigned by the wartime manpower authorities of the day to Marconi-Osram in London, and in July 1943, he started work in the Valve Development Laboratory, on prototype testing and fabrication. The work was uninspiring, but much knowledge about valve operation was gained. In April 1944, he transferred to the Applications Laboratory to design circuits, prepare application reports and assist users with application problems. This work was more interesting but was necessarily related to wartime communications problems. Williamson was still keen to involve himself in the specifics of sound reproduction. In lunchtimes and evenings, therefore, he thought about ideas for pickups, or amplifiers, or speakers, and test his ideas by constructing and refining experimental models.

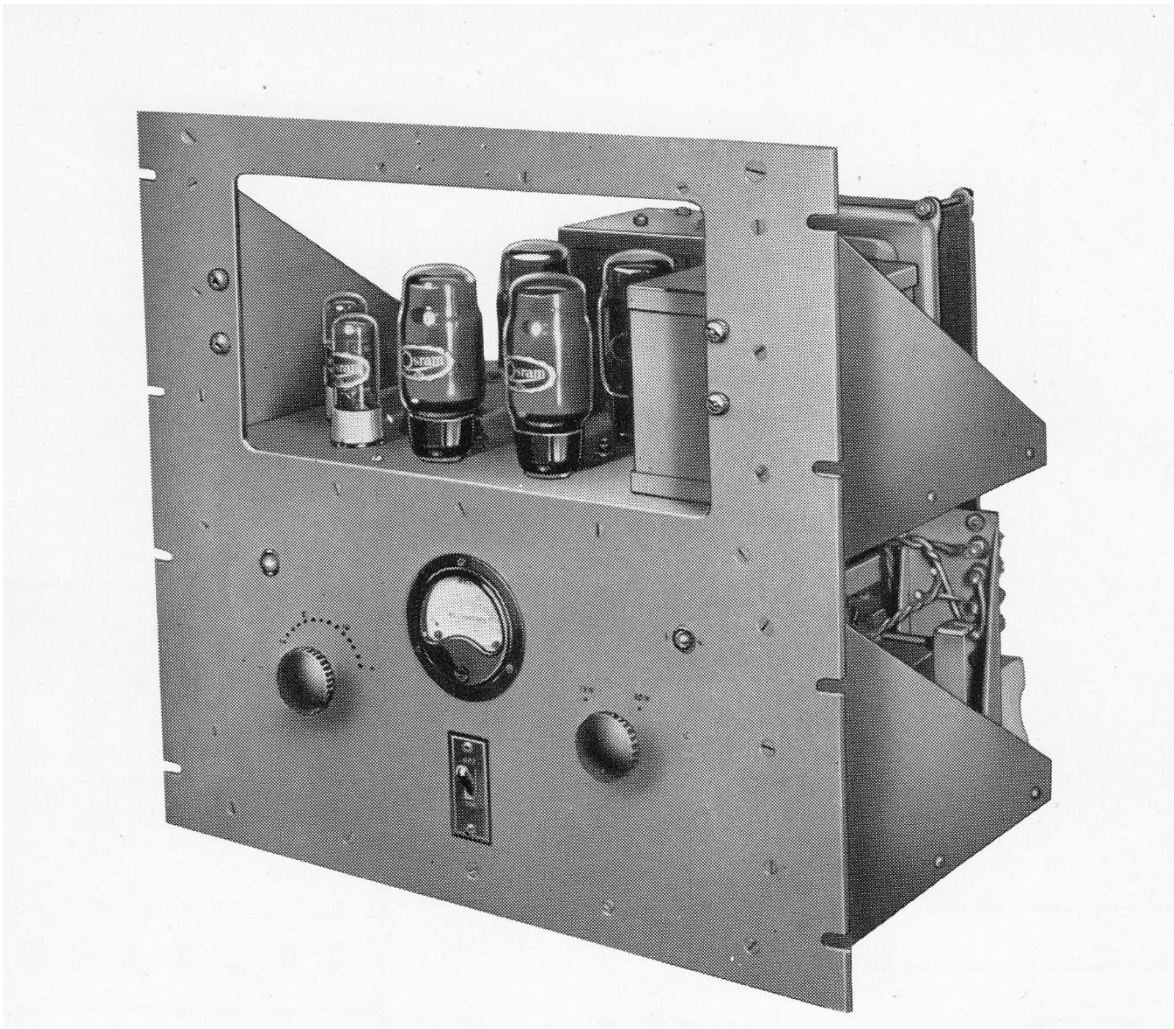

1945. An experimental 30 watt amplifier designed by D.T.N.Williamson for the Marconi Osram Valve Co. using four KT66 valves triode connected.

4. THE WILLIAMSON QUALITY AMPLIFIER. 1944-5.

Williamson's experiences and interest in the problem of amplifier quality led to thoughts for an effectively distortionless amplifier, good enough to be ignored, so that problems elsewhere in the reproducing chain could then be addressed. Making a very fine amplifier at least now seemed technically possible, whereas the problems with electro-mechanical devices like pickups and speakers were far more complex.

In contemplating a design for A.C. mains operation, it was not necessary to use tetrodes to obtain 12 watts or so of audio, enough for most speakers of the day. (Loudspeakers of the time were considerably more efficient than is typical today, and few speakers could handle much more than 12-15 watts). Triode output stages were simpler to manage, and their more amenable distortions could be very effectively dealt with by feedback, yielding an amplifier of vanishingly low distortion and providing maximum speaker damping. More stages would be required to provide the gain that would be sacrificed to provide the feedback, but it appeared that distortion levels one twentieth of the usual 2% could be achieved.

Williamson began to design and build a new amplifier this time using PX25 triodes for output. The preceding 3 stages comprised L63 (6J5) triodes as drivers, phase splitter and first stage. Since the objective was quality the design was very conservative, ensuring that no stage would be overdriven. A top quality laboratory transformer (by Vortexion) was borrowed and pressed into service and trials with feedback begun.

20dB of overall feedback was found to be the optimum value. The feedback extended the amplifier's bandwidth many octaves above the highest audio frequency, permitting excellent transient response, but the 4 stages imposed severe demands on the output transformer. It became clear that this component was absolutely crucial to the result. Phase shift at the frequency extremes needed to be carefully limited. At the high frequency end tight specification for the transformer would have to be an obligatory requirement of the design. At the low frequency end Williamson saw that his conservative stage design made possible the direct coupling of the first two stages, completely eliminating phase shift between these 2 stages.

The resulting 4 stage amplifier proved very good indeed - the testing facilities of the laboratory verified less than 0.1% distortion at around 20 watts (using 500 volts on the output stage), maintained over virtually the entire audio range. These results were so good that the obsolescent PX25's seemed out of place, and with some reworking triode-connected KT66's were substituted. With 425 volts on the KT66's, 15 watts was available with the same quality but with a modern layout.

The completed amplifier was beautifully simple in structure, contained no unknown technology, and no patentable new features, and yet could deliver the highest possible audio quality, far in advance of contemporary practice for 1944-5. The excellence of the result derived not from any single innovation but from the careful combination of the best principles of audio design of the time: Push-pull

triodes for predictable and good basic performance; overall negative feedback sufficient to remove all residual distortions, flatten and extend the response and provide excellent damping for the loudspeaker; careful control of phase; and most importantly, treating the output transformer as an integral part of the design.

This project was still only a spare-time activity of the 22 year old Williamson, with no official sanction in the Laboratory, however his boss Woodville was a very interested and supportive observer. Some concurrent experiments with a Goodmans speaker in a labyrinth baffle and a Williamson designed moving-coil pickup provided the ancillary equipment for auditions, and a preamplifier was built. This combination of experimental equipment produced a sound which was strikingly good. The experiment showed that, contrary to much prevailing opinion, the currently accepted 2-5% distortion tolerance was inadequate as a definition of high quality, and there was a definite audible advantage in lower distortion factors. With the best records (78 RPM) which could be found, treble was smoother, surface noise less obtrusive, and cleanly defined bass replaced the usual vague thumps. By mid 1945 some of the senior company staff and several visitors to the Laboratory had heard the amplifier and were impressed. One of them had some contacts with Decca and was able to obtain some experimental pressings of Decca's brand new wide-range FFRR recordings for audition and test purposes.

Official Acknowledgment. 1944-5.

Woodville's boss, Herbert Smith, asked for a demonstration of the equipment to the Marconi-Osram Board. For this purpose Williamson created a report describing the amplifier - M-O Internal Report Q253, to legitimise the project - in late 1944. The Board's reaction appears to have been one of polite interest only, perceiving no business potential for M-O in the project. G.E.C. produced and marketed amplifiers of various types for the P.A. market, and these evidently sold well enough without any pretensions to quality.

Williamson himself, meanwhile, had felt an urge to return to Edinburgh. His main duties at M-O were perhaps not so challenging any more, and the spare time activities could be picked up again later. The contacts with Decca had in fact given rise to more than one job offer from that organisation, (out of interest in his pickup designs demonstrated in some of the experimental set-ups) but Williamson declined them and in February 1946, joined Ferranti in Edinburgh, as a researcher in their Applications Laboratory. The Ferranti Laboratory was attempting to adapt wartime developed technologies to peacetime uses, and once again Williamson found himself using odd moments to think about audio ideas.

Having no ambitions as an amplifier manufacturer, his amplifier design may have remained a private project, but for later events over which he had little control.

Publication. 1947.

After Williamson's departure from M-O, one of the G.E.C. senior sales staff, F. E. Henderson, perceived that the amplifier circuit, if published, might usefully help

sell KT66's. He therefore approached the Editor of *WIRELESS WORLD*, H. F. Smith, with report Q253. Smith already knew Q253's author, (Williamson), through previous contributions and agreed to slot the article into a future edition. In the event it did not suit the magazine to print the article until April 1947, perhaps because they had already scheduled the publication of updated versions of W. T. Cocking's "Quality Amplifier". It also appears that technical editor Walter Cocking did not believe any further improvement was necessary.

Interlude - But what exactly is a Williamson amplifier?

It is easy enough to describe the topology of a Williamson amplifier but an amplifier of the required topology still might not perform to the required standard, due to constructional or other errors. In the period 1949-55 the name "Williamson" was often used loosely for any amplifier of the triode with feedback type but the name should only be used for a special subclass of triode amplifiers of high performance and having a number of identifying circuit features.

The following topological features would certainly identify an amplifier as embodying the "Williamson" design elements.

1. Four stages, input voltage amplifier, phase splitter, driver and output all operating in triode mode. The output valves may be triode, beam tetrode or even pentode types, but the latter types will be wired in circuit to function as triodes;
2. The output stage is biased for pure class A push-pull operation;
3. The first 2 stages are direct coupled;
4. The output transformer is of the highest quality and conforms to the specification for primary inductance and leakage reactance;
5. 20 dB of feedback is taken from the output secondary to the cathode of the first stage. Feedback of this degree over 4 stages is, as noted in the Radio Engineering Handbook (5e) a "severe test of design".

While there are a number of legitimate variants of the Williamson circuit, some of which will be described later, amateur "enhancements" are not generally advisable and some constructors certainly failed to appreciate this. The valve types and some circuit details can be varied but only if a complete understanding of the effects is possessed.

Control of phase shift is a critical design element. The difficulty of tightly controlling this factor with varying layouts and choice of components led to some users experiencing problems. At very low frequencies (around 2-3 Hz) any added phase shift can reduce the margin of stability to less than ideal.

With the correct transformer and care in construction the amplifier will deliver sound quality of the highest order with acceptable electrical stability. Thus the most important, and expensive, component is the output transformer, which will necessarily be of substantial size. If this component is not of the required quality, all the other features are in vain.

1948. The Classic Original.

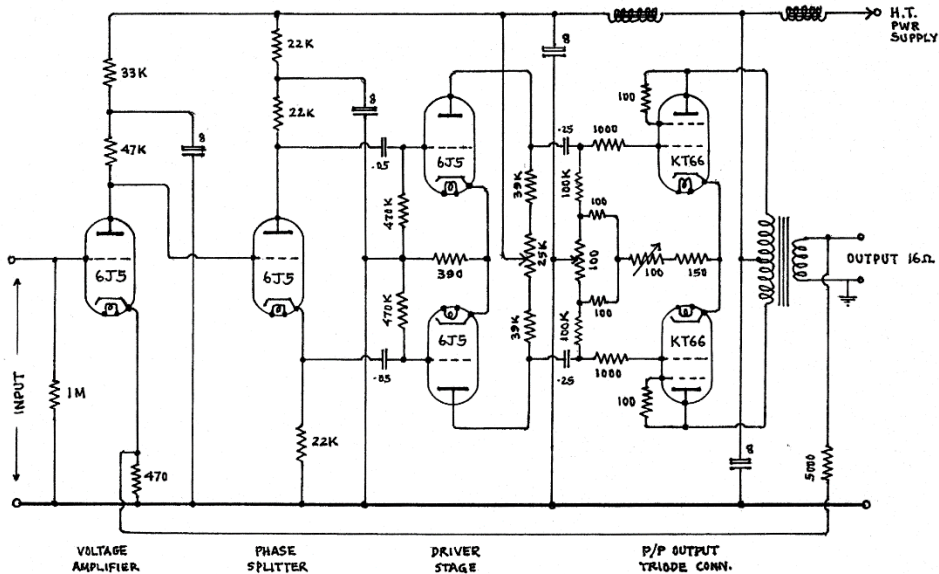

1947. The original circuit for Williamson’s amplifier as published by WIRELESS WORLD. Triode connected push pull KT66 output with 20dB feedback. An output transformer of the highest quality is an integral requirement of the design.



1948. A superbly constructed *Williamson* amplifier of the early format using four type 6J5 valves for the input stages, made by Rogers Developments, England.

5. THE POSTWAR AUDIO SCENE. 1945-7.

The Williamson circuit as it stood provided a basic power amplifier requiring 1.9 volts for full output. Interested readers needed to be able to provide the necessary preamplifier or control unit for most uses, and the not insignificant cost of a specially made output transformer would not have predisposed *WIRELESS WORLD* to expect more than a modest response to the article, and as we have noted, the published articles simply formed part of an ongoing series of quality designs which they thought would be interesting to amateur constructors, so both the magazine editors and Williamson himself were greatly surprised by subsequent events of 1948-51.

Improved recording standards 1945.

An early postwar event to draw significant attention to quality in sound reproduction, or rather the lack of it, was Decca's announcement of their FFRR recordings in early 1946, the result of wartime efforts at recording the full audible spectrum. EMI moved swiftly to counter Decca's lead with their own improved recordings. These records added 2 octaves to the frequency range and a few decibels of dynamics, but the fundamental flaws of the shellac 78 RPM disc remained. The improvement, in fact, further exposed the noise and distortion problems of the 78 RPM format, and critics on both sides of the Atlantic, though grateful for the improvements, were quick to draw attention to the remaining huge gap between recorded sound and reality.

Much of the deficit could be blamed on the shellac pressing itself (In fact, the sound captured on the wax or acetate master recording from which the pressing was ultimately derived was often very good), and on the pickups of the time, which extracted signal from the groove in a brutal and unscientific way, so as things stood the commercial record could hardly be regarded as a source of high quality sound in this period. The vinyl LP record did not appear until June 1948 (in the U.S.A.) and genuine high fidelity from records was hardly possible domestically until 1950 or so, when significantly improved lightweight magnetic pickups could be used with the improving LP record.

Broadcasting in Britain 1945-9.

A music lover's best hope for good sound quality in postwar Britain was probably a live studio broadcast from the BBC. A daytime broadcast from studio heard via a good make of wide-band receiver (not so uncommon in those days) would have had a reasonably wide frequency range and quiet background. The broadcast transmission method was AM (Amplitude Modulation) of course since FM in Britain had yet to survive a series of comparative trials in 1946-48 before being approved, and regular FM broadcasts would not begin in that country until 1955. Much BBC programming was, however, pre-recorded (on "instant recording" lacquer disc) and complaints about the wildly variable quality of these were rife.

Despite all these disincentives there was a perception that things were about to improve. The use of a silent plastic material for records was widely anticipated, though few seem to have predicted the fine groove format, and comment can be found on the superior sound quality of some television trials put to air just after the war. The sound transmission for these early TV trials was AM, (FM sound for TV came later), transmitted in the (then) uncluttered VHF band, and a wider audio frequency range was used. Certainly some workers in post war broadcasting and recording fields knew that better quality sound equipment would soon be needed, and by 1947, improved audio products were becoming more common.

U.S.A. and FM. 1946.

Things were only a little more promising in the U.S.A. with some FM broadcasts encouraging the use of better quality equipment in those centres where it was established. In that country FM had first officially gone public in 1941, and coverage was being actively expanded since the war's end, and although the engineering at the Studio end was first rate, the quality potential of FM was seldom realised at the reception end due to indifferent domestic audio equipment. The technical press was enthusiastic for FM and exhorted users to use wider range speaker systems. Unfortunately this often exposed the badness of many amplifiers in use at the time.

Postwar commercial designs - H. J. LEAK. 1945.

War-time work on general amplification matters at Marconi-Osram was not restricted or secret and the Laboratory customarily assisted any builders in the industry with applications involving M-O valves. One such person was Harold Leak whose business was manufacturing amplifiers for commercial and P.A. applications. Since 1935, his company had built to various designs including G.E.C. and Partridge circuits. The Leak factory was close-by and Harold Leak knew Grahame Woodville very well, both as a manufacturer and socially, and was well acquainted with the development of Williamson's amplifier in the M-O laboratory during 1944-5. The low distortion factor of the triode plus feedback approach (point one percent) probably gave Leak an idea for promoting his first post-war product. As the war's end came in sight, Leak organised production of an amplifier of this class.

The first version of the Leak "Point One" amplifier was announced in September 1945 and the output stages were configured in a similar way to the Williamson amplifier, having KT66 triode output with L63 (6J5) drivers and splitter plus overall feedback. The early stages and couplings were different and pentodes were used. This early 4 stage version is little known today.

This first version of the Leak amplifier was soundly made and performed as advertised, but did not have a wide margin of stability, a limitation acknowledged in later Leak promotional material. The stability problem led H.J.L. to develop a revised 3 stage design in 1947. This was the "TL12 Point One", (TL standing for "Triple Loop", a promotional way of describing the feedback arrangements). With improved stability, high gain and a simplified layout the commercial version of this

new model became a great success and firmly established the Leak name in quality audio, and from it would evolve a long and successful line of amplifiers which sold in large numbers right through to the mid 1960's. The "TL12 Point One" was used by the BBC and some other European broadcasters as a recording and monitoring amplifier, and helped forge an export market for British audio in the U.S.A.

In the late 1940's, Leak's aggressive promotion of the "point one percent" distortion factor provoked some scepticism in the marketplace as to whether this low value was necessary or indeed possible. H.J.L. countered by commissioning independent laboratory data and incorporating it into his advertisements, a successful strategy. Leak never claimed to have originated the triode plus feedback quality scheme, but legitimately claimed to have been the first maker to manufacture a high performance amplifier of this type for general use. He was a good businessman and successful, perceiving the commercial potential of a new class of true high quality audio amplifiers and following through into production.

P.J.WALKER. (Acoustical Manufacturing, later known as QUAD): 1945.

Acoustical Manufacturing had its origins in 1936 and by 1945 was making a range of good quality P.A. amplifiers, all designed by P. J. Walker. Again in 1945, Acoustical introduced a high quality version of one of their P.A. amplifiers, the M31. This design bore no relation to the Williamson or Leak approaches, but used a novel output arrangement with KT66 tetrodes, and was also able to produce some 12-15 watts of audio with extremely low distortion, and excellent electrical efficiency.

Walker had no knowledge of the other designs at the time, but had a strong personal commitment to quality. He had approached the problem from the other direction, seeking to remove the distortion artefacts from tetrode output stages, and found it possible by coupling the output transformer into both the anode and cathode circuits of the output valves. The effect is internal feedback within the output stage. In seeking a patent for the idea he subsequently found that no less a mind than Alan Blumlein had preceded him with a patent in 1937, though with a different objective. In using this principle for quality audio Walker was in fact creating a precursor to what would later become known as the "Ultralinear" format, of which more anon.

The design was refined considerably in 1947, becoming the QA12, and then with separate preamp it evolved into the Q.U.A.D. model of 1951. With still further refinement it would become the famous and highly successful QUAD II amplifier, quite a number of which are still in use today. These amplifiers became legendary for their sound quality, ruggedness and unconditional stability. They were also sold in large numbers to the broadcasting industry and their innovative designer, Peter Walker, we will meet again later in this discussion. Acoustical's advertisements of the time and later, written almost entirely by the design engineer himself, were models of clear, simple and honest technical promotion of the high fidelity approach to music reproduction from records, which at the time was still a new phenomenon.

Other Designs: 1946-7.

In January 1946 *WIRELESS WORLD* published postwar versions of their own Quality Push Pull amplifier (the W. Cocking design from 1934). The design had been updated and simplified in December 1943 incorporating a conventional input stage and was now developed into 4, 8 and 12 watt versions, still triodes without any feedback, the lower powered versions still using PX4s, the 12 watt job using PX25s. The simplicity of these designs was an obvious factor in their continuing popularity.

Some tetrode designs began to overcome earlier prejudices, with more judicious use of feedback. Altec and Vortexion produced high quality designs in this format using the American 6L6, and most new designs tended to be of this type, especially in the U.S.A. The popular electronic and hobby magazines, however, still carried much argument, sometimes heated, about triodes, tetrodes and quality.

Clearly many amplifiers of the time still produced too much distortion, and as the frequency response was extended, distortion products and noise higher up the frequency scale were being reproduced more readily. Alarming peaks in the response of the lesser pickups and speakers, often around 3-5 kHz, were common and were clinically exposed by improving the high frequency response of the amplifier.

For many users, little had changed since pre-war. They were quite accustomed to reproducing 78 RPM records with the treble severely slashed to cut the surface noise, the stridency of which was of course partly due to these same response peaks, and were unused to hearing extended high frequencies from broadcast or records. If the equipment was incapable of delivering high frequencies without a generous helping of shrill distortions, it was hardly surprising that many preferred to do without a large chunk of the treble spectrum. A poor tetrode design would clearly be a guilty party in this process but their bad reputation probably owed something to the badness of much of the associated equipment. With FM in the U.S.A., early receivers were seldom drift free, and the harsh distortions which result from mistuning would be cruelly exaggerated by amplifiers with extended frequency response.

Nevertheless by 1947 the quality seeker had a small selection of good amplifiers to choose from, providing one had access to programme material, pickups and speakers to make it worthwhile. Commercial amplifiers of quality were quite expensive however and the highest quality in amplification was beyond the reach of many. The belated emergence of the Williamson design in April 1947 made a big change in this latter market, since the amplifier could be constructed by the hobbyist for little more than half the cost of the commercial jobs.

6. EARLY REACTION TO THE WILLIAMSON AMPLIFIER: 1947-8.

In Britain, some readers of the original *WIRELESS WORLD* article had certainly found it intriguing and began building immediately. By September 1947 Partridge had modified the wording of their customary advertisements to state that they could supply transformers for the "Quality Amplifier", clearly in response to demand.

Response in Australia. 1947.

Obviously we will not find much mention of the Williamson design in other British journals of the time. The Australian technical radio press, on the other hand, were only too pleased to seize onto any new audio design from overseas. In August 1947, *AUSTRALASIAN RADIO WORLD*, a Melbourne publication, printed a fairly full description and circuit details with some enthusiasm though they commented on the difficulty for local users of obtaining either the British valve types or the transformer core materials in a severely constrained postwar Australia, and considered the possibility of using the plentiful RCA 807 for the output valve. Quite how they managed to get the details into print so soon after the *WIRELESS WORLD* articles is slightly mystifying.

About the same time, August-September 1947, in the Applications Laboratory of Amalgamated Wireless Valve Coy (a division of A.W.A., Australia), Fritz Langford-Smith took an interest in the Williamson design and had the Lab. staff develop a version, necessarily avoiding the use of the English valve types and using their own (i.e RCA) types. They used the RCA 807 for the output stage, double triodes (6SN7's) for the other stages, and used the best transformer they could find in the laboratory, but stuck closely to the principle of the original design. The power output of this version was slightly lower than the original at 10-11 watts, but still sufficient for most domestic purposes. This circuit was given their code number A515. In November-December the Lab. published their findings in A.W.V's trade pamphlet *RADIOTRONICS*.

The *RADIOTRONICS* article is quite unequivocal; "The best amplifier we have ever tested" they stated. In the same month, December 1947, advertisements for suitable transformers appeared in *AUSTRALASIAN RADIO WORLD* for Redline (Swales and Swann Ltd, Melbourne). Even though the *RADIOTRONICS* article specified manifestly different valves, it very clearly attributed the excellence of the result to the design principles of Williamson.

In January 1948, *RADIO AND HOBBIES* magazine (later known as *ELECTRONICS AUSTRALIA*) published details of the A.W.V. A515 design, again with some enthusiasm, and in March-April published their own version with a preamplifier stage as well. In February 1948 *AUSTRALASIAN RADIO WORLD* also published

details of A515 under the heading "Stir in HiFi Circles". In most of these items the origin of the design was properly attributed to Williamson.

First commercial versions. England 1948.

In *WIRELESS WORLD* for February 1948 the first advertisement for a fully built up version of the amplifier appears for a small firm (Dismore's) and in March another (Elmsleigh's). The first name that we would recognise today to take up the design was Rogers, who offered a "Williamson" design in October 1948, along with their own and Partridge circuits.

THE "WILLIAMSON" AMPLIFIER

If you are very critical of the reproduction from the average "quality" amplifier, this is the instrument for you. The designer claims this to be "virtually distortionless," to which we would add that the "attack" and transient response sets quite a new standard. We are now producing this amplifier to specification with first-grade components in chassis form at :—

£27 . 10 . 0

We shall be happy to arrange demonstrations by appointment.
Orders are being handled strictly in rotation. A limited number of acoustically designed cabinets are also available.

L. P. DISMORE
(formerly MORTON & DISMORE)
52c Oldchurch Rd., Chingford, E.4
Phone : SIL. 4987.

Advertisement in *WIRELESS WORLD* February 1948

**THE
WILLIAMSON AMPLIFIER**

and
**GOODMANS and BARKER
BASS REFLEX CABINETS**

The above are now being demonstrated daily.
Illustrated leaflets dealing with both are available on request.

The Williamson amplifier is built by craftsmen, the workmanship being of the finest standard, with Partridge transformers and chokes used throughout in its construction.

ROGERS DEVELOPMENTS CO.
106 HEATH STREET, HAMPSTEAD,
LONDON, N.W.3.
Telephone : HAMPstead 6901

Advertisement in *WIRELESS WORLD* November 1948

1948. The 807 version.

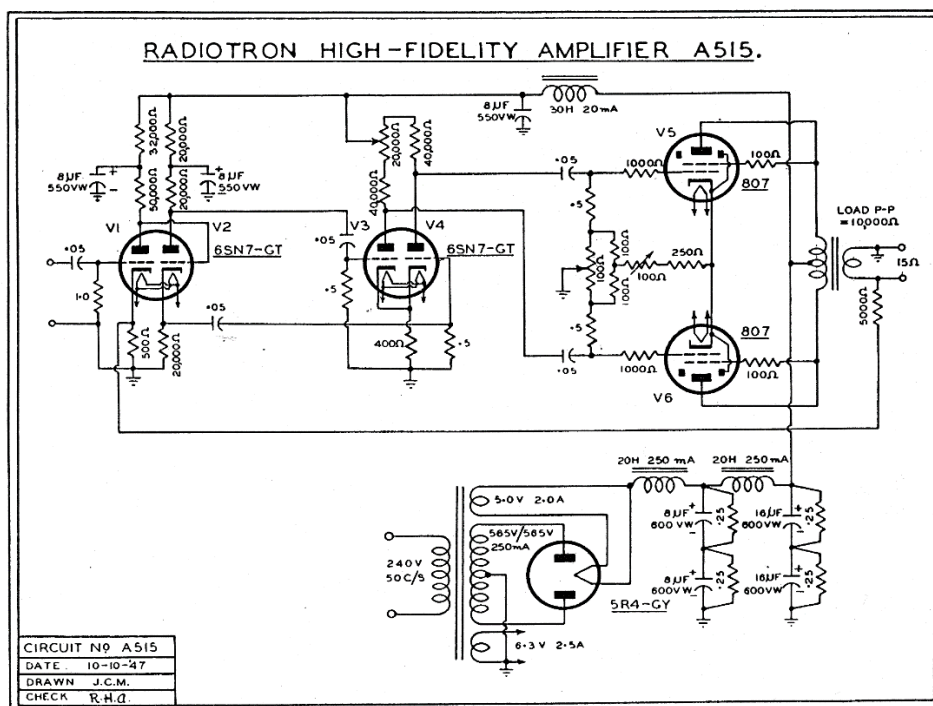

1947-8. The A515 circuit format of the *Williamson* amplifier as developed by the AWW Laboratory, Sydney, with double triode 6SN7 valves for input and type 807 valves for the output stage. It is functionally essentially identical to the original.



1948-9. A *Williamson* amplifier of the AWW A515 format, as popularised by "Radio & Hobbies" magazine in Australia. Built from a kit offered by Price's Radio, Sydney.

7. THE PROGRESS OF *THE WILLIAMSON*. 1948-51.

Following the publication of the 1947 articles, the Editors of *WIRELESS WORLD* found themselves dealing with an ever increasing stream of reader inquiries about the new amplifier design and soon resorted to redirecting the flow back to the designer himself, thus no follow-up articles and very little correspondence can be found in the magazine itself. By mid 1948 it was clear that the Williamson design was attracting an altogether unusual degree of interest in both amateur and commercial fields, and Williamson had to deal with queries on aspects of the design from all quarters of the globe. Many of the queries concerned suitable preamplifiers and thus he found himself working on some supplementary circuits on a part-time basis over 1948-49.

In August 1948 *WIRELESS WORLD* published yet another quality design, this one contributed by Peter Baxandall, another name which would become known world wide in this field. His design was definitely unorthodox for the time. It was a 2 stage job with push-pull 6L6 tetrodes for output, but used 36dB of feedback from a specially positioned tertiary winding in the output transformer. The tertiary winding was arranged in a way which avoided phase shifts, and thus despite the very high feedback factor, full stability was claimed. About 10 watts was produced with 0.1% distortion at 40 Hz from a 4 volt input.

The transformer design, despite the extra winding, was not unduly complex, and the principle involved was attributed by Baxandall to a BBC patent. It seems probable that the high feedback factor frightened off many constructors and its acceptance was somewhat limited. Baxandall asserted that this degree of feedback was required if tetrodes were to match the quality of the triode+feedback arrangement, and his solution must have seemed radical at the time.

A number of designs appeared subsequently with tetrode/pentode output with 20-25 dB of feedback, resulting in about 0.5% or so of distortion of unspecified orders - mainly in the U.S.A. None of these amplifiers, while popular, seems to have survived with a particular reputation for the highest quality of sound, at least with the valve types and transformer technology available until 1954, and to some extent thereafter. Only those which employed some supplementary feedback mechanism (such as the cathode loading scheme used by QUAD and BOGEN for example) seemed to produce results which could stand direct comparison with the Williamson and Leak (triode) approach. Baxandall's observation, though radical for 1948, would later be validated with the emergence of the so-called "Ultra-linear" output stage of 1951.

New coverage. 1949.

The swelling tide of inquiries brought forth a further series of articles from Williamson in *WIRELESS WORLD*, August to December 1949. These described a slightly updated amplifier, a preamplifier design, an AM tuner design and provided some general answers to the most typical queries. Ferranti had been co-operative and Williamson was able to develop and test the new circuits in their laboratory.

The changes to the power amplifier were minimal, mainly the adoption of an indirectly heated rectifier, and the nomination of some alternative valve types.

The 1949 preamplifier did not attempt any provision for Long Play records. This may seem a little curious since the 1947 articles had strongly hinted at a new disc format, but Britain appears to have been largely in the dark about LP until early 1949, and with E.M.I having subsequently declared themselves opposed to the new format, its future probably seemed uncertain.

It is evident from the 1949 articles that some constructors had experienced stability problems with the main amplifier due to use of output transformers not having the required characteristics, though it had been documented repeatedly in every constructional article that the quality of this component was absolutely crucial. The misunderstanding of this requirement was to haunt the design throughout its career.

The additional circuits providing a complete system made the design even more attractive to general constructors, and the existence in the market of ready made transformers and commercial versions (which generally acknowledged the origin of the circuit) provided for a tide of new interest which by 1950 became something of a flood.

A number of English amplifier makers now offered models based on the Williamson circuit for their highest quality applications. Rogers produced extremely well built Williamsons. Goodsell, EMG and Expert were other well known British makes of the time to use the design or its principles.

RED LINE EQUIPMENT

for

THE NEGATIVE FEEDBACK AMPLIFIER *

● OUTPUT TRANSFORMER

Primary Impedance 10,000 Ohms 807 (T) P.P.
Secondary Impedance 15 Ohms * + 34 db.

Frequency Response: Linear within 0.2 db.
20 cps. to 30,000 cps.

Primary Inductance: (at low ac flux) not less than 125 Henries.

Leakage Inductance: 17 Millihenries.

Insertion Loss: 0.4 Decibels

This transformer may be used to obtain a gain reduction of up to 25 db. across 4 Stages in a suitable negative feedback circuit.*

* In 500 Ohm Line if required (AF10)

● POWER TRANSFORMER
10v, 210v, 230v, 250v, 50 cps. Sec.
H.T. 500/500v at 175 ma. 5v 3a 6.3v;
2a 6.3v 3a

● FILTER CHOKE
12 Henries
175 mA Type 201515 £1/11/-

● SMOOTHING CHOKE
25 Henries
60 mA Type 50825 £1/7/-

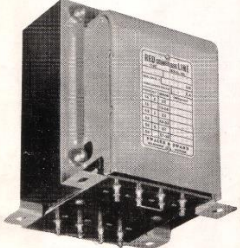

TYPE No. AF15
Weight 7 lbs. Price: £6

A Choke Input Power Supply shown in Radiotronics 128 requires:

Power Transformer, Type No. 17503 Price £3/12/6

Choke (1), Type No. 201515 Price £1/11/-

Choke (2), Type No. 201515 Price £1/11/-

Choke (3), Type No. 50825 Price £1/7/-

RED LINE EQUIPMENT PTY. LTD.

Incorporating Swales & Swann

Workshops:
2 Coates Lane, Melbourn
Cen. 4773



City Office:
157 Elizabeth St., Melbourn
MU 6895 (3 Lines)

A GUARANTEE OF DEPENDABILITY

The Australasian Radio World, March, 1948 Page 43

Advert Australasian Radio World March 1948

1950. Some Commercial Examples



1950. A *Williamson* amplifier marketed by Goodsell, England. This variant incorporates an auxiliary rectifier 6X5 valve (2nd from left) for powering attached pre-amps etc.



1950. A *Williamson* amplifier in the slightly revised British format. Marketed by Audio Engineers Pty Ltd Sydney.

8. THE WILLIAMSON AMPLIFIER IN AMERICA. 1948-51.

Prior to 1950 British equipment and designs were not widely known in the U.S.A., except perhaps to subscribers to *WIRELESS WORLD* and one or two other British journals, thus early information about the Williamson amplifier would not have been common. There does not appear to be much mention of it by the major periodicals until 1949. British valve types such as the KT66 were not generally available and obliging (small volume) transformer makers were not so easy to find, so that building a Williamson presented some difficulties for the few who were aware of the design anyway. Nevertheless, by mid 1949, some had been built, though how many conformed to the circuit or general requirements cannot be known.

RADIOTRONICS presumably had a small circulation to laboratories in the U.S.A., and RCA technical papers doubtless reproduced material from it on occasions, and it was the A515 version of the Williamson which first appeared in the American context. In August 1948, the monthly *AUDIO ENGINEERING* (later *AUDIO* magazine), published some comment on the (Australian) AWA Radiotron Laboratory's analysis of the A515 amplifier, i.e. the good measured intermodulation distortion performance, compared to contemporary designs, but only sharp eyed readers would have spotted it.

In August 1949, *RADIO-ELECTRONICS* (formerly *RADIOCRAFT*) published a design for a complete high fidelity tuner-amplifier, quite an elaborate affair. The fairly low-key article notes that the audio stages are "based on a design by D.T.N. Williamson from *Wireless World* (London)" and in fact the circuit shows the amplifier section to be essentially identical to the *RADIOTRONICS* A515 version, which you recall employed American valve types (RCA 6SN7, 807). The article provides little quantitative data on performance but draws attention to the use of substantial feedback with triode output mode, noting that the improvement over conventional triode output "has to be heard to be appreciated". Clearly, even close to 1950, American practice still regarded this to be an unusual configuration.

"The Musician's Amplifier". 1950.

In November 1949, the first of a series of Articles called "The Musician's Amplifier" appeared in *AUDIO ENGINEERING*. In these items the exceptional audio quality of the Williamson design was the main theme. The articles commented on the popularity of the Williamson amplifier achieved in Britain and Australia and detailed the construction of a unit also clearly based on the A515 version. The article was accompanied by advertisements for suitable transformers, and for fully built up amplifiers (made by a firm operated by the authors of the article of course) so that readers could act immediately to build or buy the amplifier.

And they did. It seems there was a hunger for just such an amplifier which could deliver uncompromised quality at a reasonable price. Very quickly indeed, the

Williamson amplifier became a subject of much discussion and activity. The prestigious position of *AUDIO ENGINEERING* may have been a factor in the rapid acceptance of the design, just as *WIRELESS WORLD* had lent its authority to the design in Britain, but the other journals now took an interest too.

Other designs in the U.S.A., 1948-53:

In the very next month, *AUDIO ENGINEERING* published details of another approach to high quality amplification. In this issue McIntosh and Gow gave a full account of their new McINTOSH 50W-1 amplifier, the first of a line which was to become one of America's most respected. This amplifier was unique, an elaborate design which contrived to remove the defects of class B operation and produced 50 watts from a pair of 6L6 tetrodes. Description of the purpose designed transformers and feedback topology of the final stages occupied about 5 pages in the magazine. The resulting amplifier achieved wide recognition for performance and efficiency and received wide application in recording, laboratory, cinema and domestic fields. For domestic use it was, however, very expensive even for the U.S.A., costing \$300 (in 1949) compared to Sun Radio's Williamson unit at \$120, and your garden-variety of "HiFi" at about \$50.

BROOK were offering a 10 watt design, all triodes with feedback, and a bigger unit operating into class AB with an elaborate automatic variable bias system for the output stage designed by Lincoln Walsh. This larger design actually dated from 1946-7 and was a fairly complex solution, involving specially made interstage transformers as well. BROOK were strong proponents of the triode+feedback format through 1947-53. WHITE SOUND offered a bi-amp system, a 10 watt chassis for bass and a 7 watt chassis for top, with triode amplifiers. BOGEN were to offer a design with similar output arrangements to the English QUAD. By 1951 both the QUAD and the LEAK British amplifiers were being marketed in the U.S.A too.

Ascendancy. 1951-2:

By 1951 a number of the established makers were offering Williamson based amplifiers. The early offerings followed the A515 circuit, generally in dual chassis form (separate power supply), but units based on the original KT66 version began appearing soon after. GROMMES, PILOT and CRAFTSMEN offered such versions. SUN RADIO and HARVEY RADIO were well known "HiFi" vendors of the period, actively promoting Williamson format amplifiers.

By this time the Williamson is well established as the quality standard for high fidelity amplifiers. The world-wide demand for data on the designs was now so strong as to require *WIRELESS WORLD* to produce a reprint of all the Williamson articles in booklet form, some 36 pages of it. Various OSRAM and G.E.C. pamphlets had also provided a number of different versions of the basic Williamson design.

9. THE ULTRALINEAR ERA. 1951.

In November 1951, *AUDIO ENGINEERING* published an article by David Hafler and Herb Keroes giving details of an output configuration for tetrodes which, while retaining their efficiency, had low distortion performance more like triode operation. This was achieved by tapping the output transformer primary and feeding back a proportion of voltage to the tetrode screens, yet another system of feedback within the output stage. Hafler and Keroes, both then working for ACRO PRODUCTS, dubbed this the "Ultralinear" system. This arrangement gave very low distortion with about double the power capability of the same valves used in triode configuration, thus a pair of KT66's connected "Ultralinear" could produce some 25-30 watts of clean sound compared to 12-15 watts as triodes. The underlying principle once again related back to Alan Blumlein's 1937 proposal, (to reduce the output impedance of an amplifier), and this precedent prevented the patenting of the new circuit in Britain, but a patent was granted in the U.S.A. The new circuit had the advantage of being simpler than the previous realisations of the principle. David Hafler's later enterprise, DYNACO, subsequently produced many highly regarded amplifiers using his Ultralinear principle.

Despite some initial uncertainty about how and why the new circuit actually worked, it appeared quite easy to implement on most high fidelity amplifier output stages using tetrode valves, sometimes requiring only a replacement output transformer, though stability problems sometimes needed attention in such conversions. Ultralinear output was rapidly adopted by many amplifier makers. The quality of sound derived was judged by many to be as good as the Williamson, though it was certainly no better, and the extra power was a benefit which could not be ignored.

Being the established standard, the Williamson design continued to be popular, thus versions with doubled output stages appeared in a number of periodicals, for those who felt they needed more than 15 watts. Some years previously Williamson had constructed just such an amplifier for his own use. With 500 volts of high tension on six KT66 valves 60 watts was obtainable. Commercial makers would not normally have used such high voltages and would have been content with somewhat lower output.

Models appeared labelled "Ultralinear Williamson", but such a beast cannot really exist. An amplifier can be Ultralinear (tetrode operation) or Williamson (triode) but hardly both, but the notion was clearly intended to imply that the quality of the Williamson was retained, plus the increased power of the new circuit. An amplifier so labelled was usually the basic Williamson format converted to tetrode operation with an Ultralinear pattern transformer. Inevitably there were also a few occasions when the description was used in a totally spurious way, since there was no patent or copyright in force.

The twilight of a controversy. 1952.

Many would-be high fidelity enthusiasts were confused by the arguments about amplifier types, and wanted some guidance on whether Williamson or Ultralinear approach was best. Sensing this, Williamson and Peter Walker (who were, by 1952, collaborating on the QUAD electrostatic loudspeaker project) produced an article for *WIRELESS WORLD* to explain the merits of the 2 approaches. Though chiding the use of this doubtful term "Ultralinear" as a circuit description and pointing out, politely, that the underlying principle was not really new, they concluded that any sound quality differences were inconsequential, that the Williamson approach was best for the home constructor, due to its simplicity, and the tetrode approach was appropriate for the fully manufactured amplifier, where circuit and transformer tolerances could be carefully balanced. A nice compromise, and quite correct. The article was published in September 1952. Earlier in that year (May) *WIRELESS WORLD* had published a supplementary article from Williamson outlining LP provisions and further preamplifier facilities, following EMI's belated capitulation to the LP disc format.

The initial suspicion about the Ultralinear format, possibly deriving from the impression that it seemed to be giving something for nothing, was overcome with wider understanding of its function. The new amplifiers were able to compete with the Williamson for quality because of the additional feedback within the output stage together with some 25 dB or so of overall feedback usually employed. It was this additional feedback in the output stage which made the difference from the conventional tetrode amplifier with feedback, ensuring that distortion products were well below 0.5% at all frequencies.

David Hafler himself, however, maintained a view that the Ultralinear arrangement was a unique operating condition for valves, giving the stage new performance characteristics for which the 'internal feedback' concept of its operation (alone) could not account. Later analyses by Crowhurst and others seemed to support this.

In due course Ultralinear finally seemed to put to rest most of the old triode/tetrode/pentode arguments. From this point tetrode and pentode output stages were generally accepted and deemed "respectable", although curiously, as late as 1961 the MARANTZ company in the U.S.A. still offered an amplifier which could be switched by the user between triode and ultralinear output operation. The performance of the amplifier (the Model 9) was superb in either mode, and very few users would have opted for the lower power delivery of triode mode.

After 1952 most commercially manufactured designs using the Williamson or Ultralinear pattern used KT66's for output and two 6SN7 double triodes for the pre-stages, making a fairly compact, if heavy (10-15 kg) amplifier. Kit makers HEATH and ALLIED offered both Williamson and Ultralinear formats concurrently.

An authenticated version: 1953.

In 1953, perhaps just past the zenith of the Williamson career, an organisation named British Radio Electronics marketed an amplifier in the U.S.A., named the "WILLIAMSON HALLMARK" which claimed the distinction of being an authenticated version with Williamson's signature engraved on the badge. British Radio Electronics was the brainchild of an expatriate British ex-Serviceman friend of Williamson. The amplifier was actually built in England by Peter Walker's Acoustical Manufacturing Co., with Williamson's agreement, in a sturdy 2 chassis format. It might have been a success, receiving a good review in *HIGH FIDELITY* magazine, but the price in the U.S.A. was too high. At \$169, compared to American built versions at about \$120, not too many buyers were found. This price included a preamp which was, in fact, the QUAD II (mono) preamp slightly modified and rebadged with the "Hallmark" name to match the power amp. (Walker's QUAD II amplifier was also being marketed in the U.S.A. by this time).

Innovation and Imagination 1953-58.

A large component of the cost of all quality amplifiers was the output transformer, the very specialised core material alloys and complex winding patterns of the best types making them very expensive. Eliminating the transformer became the subject of much discussion and experiment. PHILIPS and STEPHENS produced designs using their own speaker models with high impedance voice coils, but those designers who strove for low impedance transformerless output stages found that the complexities entailed could only be justified in a "quality at any cost" design, and that market was too small in the 1950's for many designers to persist. Transformerless valve amplifiers would remain an expensive rarity.

Circuit innovation became very marketable in the U.S.A in the middle 1950's, and there was a rush of designs featuring variable bias, variable feedback and variable damping and other ideas. ELECTRO-VOICE produced one of the most sophisticated designs, dubbed the "Circlotron", with the output valves and transformer in a bridge configuration. In other cases the "innovations" seem to have originated from the advertising department rather than the design engineer. Feedback was now aggressively emphasised in advertisements, some makers claiming 40 and 50 db in their designs, but several of these claims were definitely misleading, to say the least.

New smaller 9 pin valves were now becoming available for high fidelity power applications. In 1954 G.E.C. publicised a design using the new valves under both G.E.C. and OSRAM banners (the OSRAM 912) which used the Ultralinear format. Ironically the pamphlet quoted verbatim large sections from Williamson's 1947 articles, as did several other G.E.C. publications from 1950-54, without credit to the original author until the end of this period.

In 1955 MULLARD introduced their 20 Watt amplifier design, (once again through the pages of *WIRELESS WORLD*), also using Ultralinear format with their new EL34 (or 6CA7) output valve. The Mullard literature gave very detailed analysis of

the output stage, preferring the more useful description "Distributed Load". Another popular Mullard design, the "5-10" started life in 1954 with EL84 (6BQ5) pentode output but with uncertain stability margins, and was subsequently offered in improved form with distributed load output. The Mullard circuits were subsequently published independently with full constructional details, proving very popular, and were taken up by many amplifier makers in Britain and overseas wishing to offer the Ultralinear format. Even Harold Leak had converted all his designs to use the Ultralinear output stage in the last couple of years.

The new smaller and more rugged valves helped create more compact amplifiers and with the coming of stereo in 1957-58 compactness and economy would be paramount requirements for amplifiers. The Williamson circuit, though still acknowledged as unbeatable for quality, became less common. Kit makers like Heath were still offering Williamson types up to the 1960's.

Stereo to Solid State 1958-68:

Continuing improvement in transformer design and fabrication, and the newer valve types permitted straight pentode+feedback output stages (without Ultralinear connection) to produce respectable amplifiers, often operating into the class AB region for a slightly higher peak power capability. Fisher, Scott and a number of others makers in the U.S.A. produced models of this type which were very well received. The old pentode bugbear of output impedance sensitivity had been substantially overcome with the more recent valve technology. These amplifiers were compact, economical and reliable and performed well, perhaps falling short of the very highest sound quality standards only by a small margin. As far as I can tell McIntosh were the only maker to successfully use a design based on class AB2 operation for the highest quality applications. Only by using their very specialised circuit and transformers were they able to provide the necessarily drastic feedback mechanisms and circuit conditions to guarantee performance and stability. It was a brilliant design. They continued to produce fine valve amplifiers into the very late 1960's and beyond.

Transistorised input stages in amplifiers started to emerge in the early 1960's and the solid state revolution was well under way by 1965. The very low efficiency speaker systems which had been developed since 1954 created a demand for power outputs which could not be economically delivered by valve based amplifiers. The new transistor technology brought with it some new problems and controversies which continue even today.

10. CONCLUSIONS.

In 1947, when the Williamson design became known, there were one or two amplifiers in the same league (for quality), but they were not universally known. Neither the Leak nor the Acoustical designs were all that well known except in Britain, since there was hardly any "HiFi" press or literature at that time. The "HiFi" business was certainly up and running in the U.S.A. and there were some recognised makers such as Altec and Brook, but in neither country were there many widely recognised consumer products representing the standard of excellence or comparison. There were very few audio products well known on both sides of the Atlantic.

In 1947, the Williamson triode+feedback approach was not new, amplifiers of this general class were available. Even in 1944-5 when it was developed, other designers may have been working along similar lines and achieving comparable results, so why was it that the Williamson design became elevated to that universal standard of excellence?

The Williamson design took hold in Britain because it was available to constructors for almost half the cost of the commercial products, and offered sound quality which could not be bettered by any commercial, or for that matter professional product. Further, the basic triode output format was well understood, simple and well trusted, so the design avoided any lingering mistrust of tetrode and pentode formats. The responsiveness of quality component makers such as Partridge must have contributed to the early acceptance, and as the design was effectively in the public domain, commercial makers were also able to respond quickly to supply those who wanted a ready made unit.

The quick development of a version using the cheap and plentiful RCA 807 was an important factor in allowing adoption outside Britain, since in early post-war times the KT66 was difficult to obtain overseas. This version became well established in Australia/N.Z. in 1948 and initiated the invasion of the U.S.A. in 1949. In the U.S.A. too, the Williamson caught on because of its quality of sound, it was obviously and audibly better than almost all contemporary amplifiers of 1950. Even at this late date, harmonic distortion factors of 2-5% were still commonplace for so-called "hifi" amplifiers.

With this world wide acceptance of the design, we have, for the first time, an international standard of comparison and of excellence in audio, available to the widest public through being available in built-up, kit and component forms. It was a truly international audio component, and it may not be too far fetched to suggest that it created the international dimension in audio.

Part of Williamson's 1947 published article presented a definitive set of requirements for a high quality amplifier. Williamson's careful and logical presentation of these requirements was important in four senses;

- 1: They fully defined the scope of the qualitative performance standards necessary to properly describe "high fidelity" amplification, which in its essentials has applied ever since;
- 2: They reset the acceptable working values of those performance standards to a level which is still valid today;
- 3: The high standard so defined created comparable expectations for the other components in the audio chain (even though unachievable at the time) and;
- 4: The wide circulation disseminated an understanding of the requirements to professionals, amateurs and consumers worldwide.

From the foregoing I hope that I have shown that the Williamson amplifier modified audio history in a way which very few single designs or products have, through a combination of simplicity, quality and accessibility. We have traced many important events and products which deserve better documentation, and perhaps these notes will help highlight part of the contribution of Theo Williamson to the good audio that we take for granted today.

ACKNOWLEDGEMENT:

My sincere thanks to Dr Williamson for his generous help on biographical and technical details in the preparation of this paper. I take responsibility for all opinions expressed however. P.R.S.

February 1991

POSTSCRIPT:

As mentioned in the introduction, Theo Williamson also contributed other important audio designs until the mid 1950's, all as part time projects, secondary to his principal field of work. One cannot help wondering what might have emerged had he been inclined to specialise full time on audio challenges.

After 1955, and still only 32 years old, his work with computer control of machine tools became too pressing to leave any scope for audio projects, and he was to become a major innovator in this field until his retirement. He has worked in many major scientific committees and projects sponsored by British and European Governments, which led to his appointment as a Fellow of the Royal Society in 1968, one of the highest of scientific distinctions.

A FURTHER POSTSCRIPT, 1992.

Dr D. T. N. Williamson D.Sc. F.R.S. lived quietly in Italy, still interested in all facets of high quality music reproduction until his untimely death in May 1992.