

# Adjustable crossfeed circuit for headphones

When listening to speakers, the right ear can hear the left speaker and vice versa. The duplication of this effect prevents the in-head localisation phenomenon while listening to headphones. The signals that are cross fed are passed through filters that provide some low-pass filtering and delay in the signal path from one channel to the other. One of the earlier circuits was suggested by Linkwitz [1] and explained in great extent. After that, other circuits were proposed [2-6] in attempt to emulate the same natural crossfeed. It turns out that they have rather different frequency responses.

The survey, composed from twelve different circuits [1-6] is shown in Figure 1. The low-pass filter is varied from 200Hz to 1000Hz and low frequency attenuation as varied from 0dB to 12dB.

It seems interesting to build a circuit, which crossfeeds the input signals, while the low-pass filter and crossfeed attenuation are adjustable. One of the possible circuits is shown in Figure 2. This circuit does not have the direct signal high-frequency rise, which is inherent to the most of realisations. This high frequency boost (up to 6dB) can be too bright.

Crossfeed can be adjusted by frequency control VR1, VR4 and level control VR2, VR5. It was found that feeding the circuit only from one stereo channel during adjustment (by input push-button SW1) helps placing the position of sound image. Both frequency and level controls allow changing the spatial width of the solo musical

instrument (e.g. piano) or soloist. The crossfeed can be disabled by the switches SW2, SW3 for true binaural recordings or other surround sound sources.

The op-amps can be any type, unity-compensated, as they work with low-frequency spectrum and their load is insignificant for generating perceptible distortion. Any of the existing phone amplifiers can be used after volume control.

**Dimitri Danyuk,**  
Kiev  
Ukraine

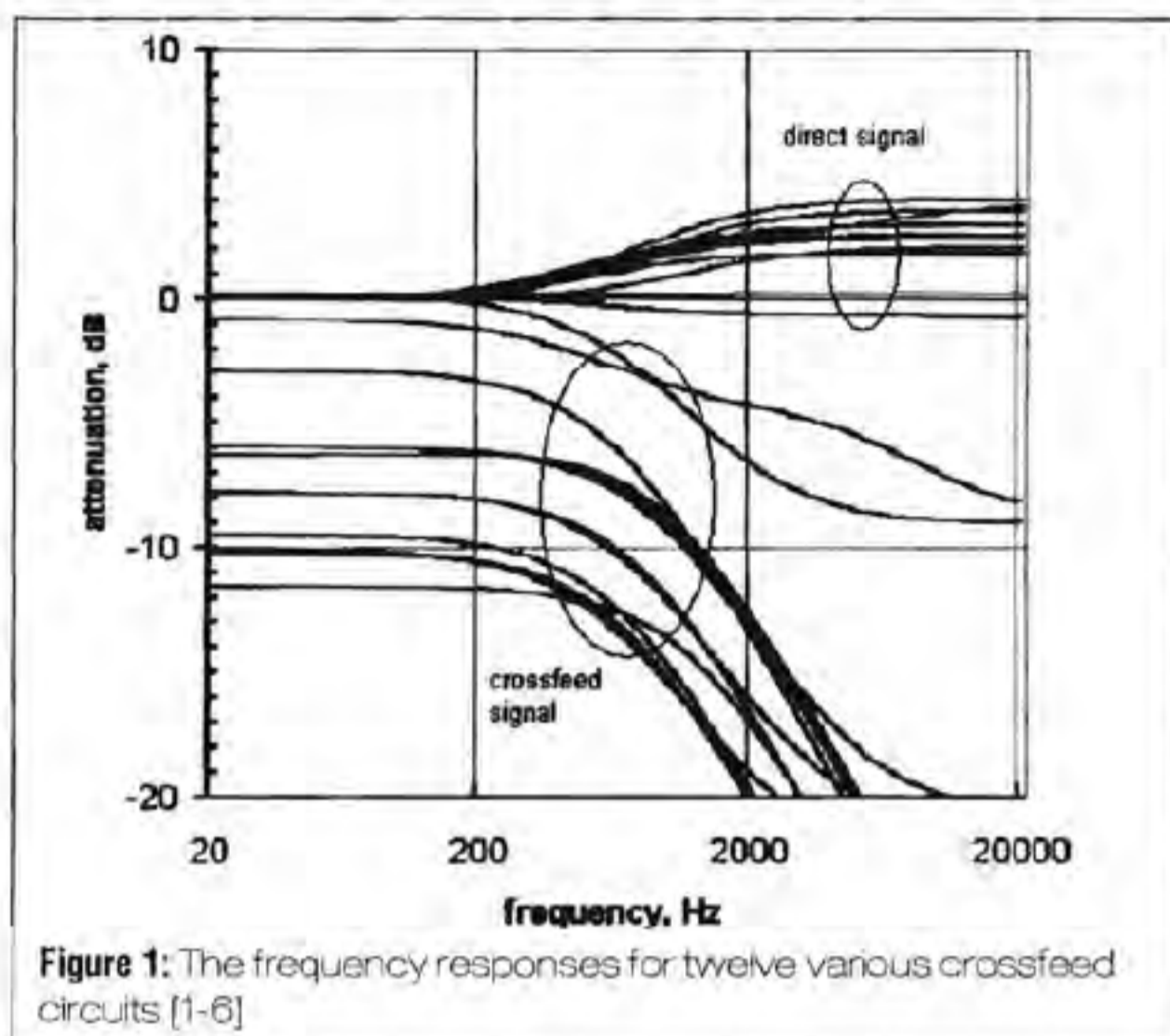
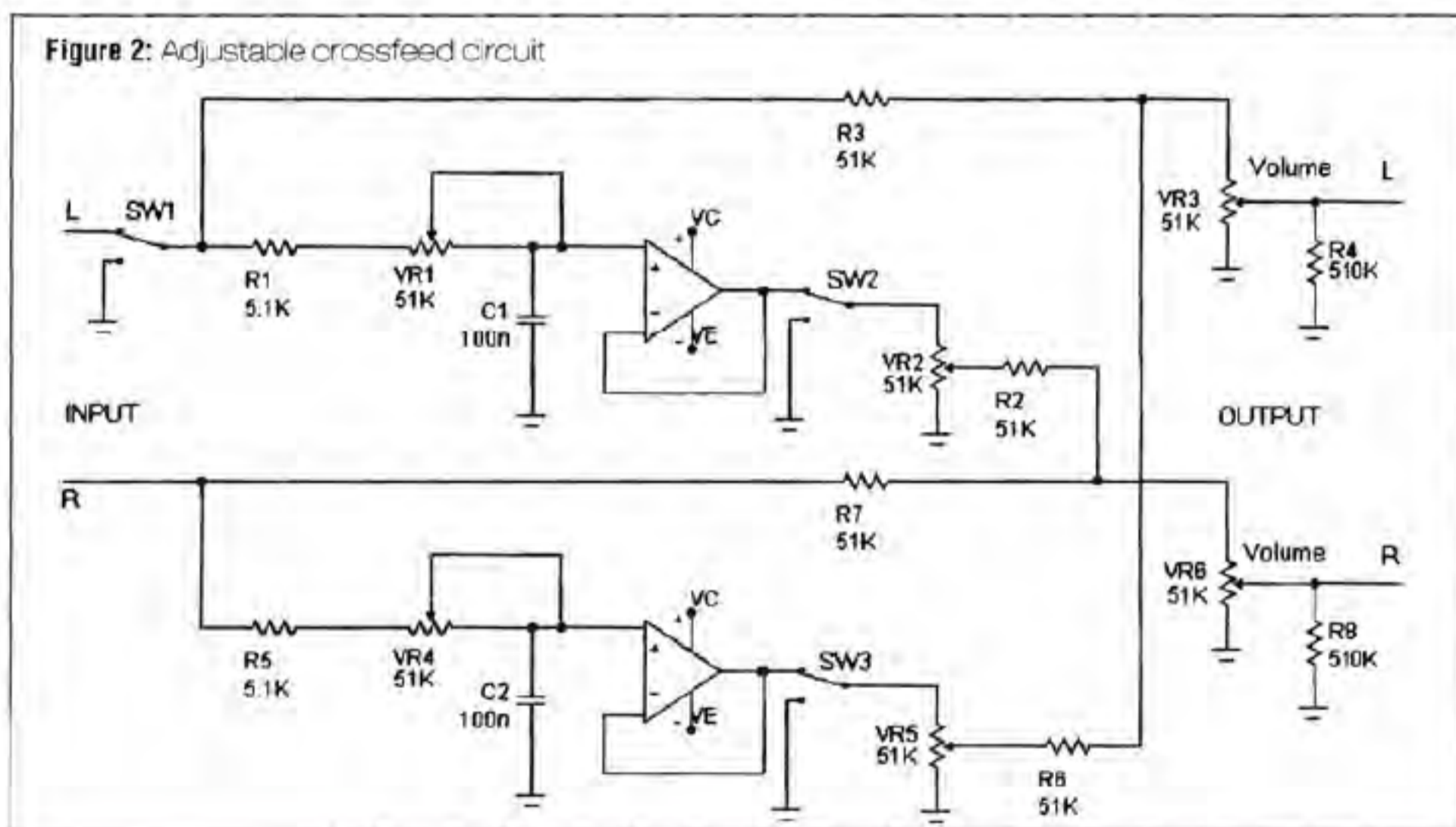

Figure 1: The frequency responses for twelve various crossfeed circuits [1-6]



## References:

- [1] S.Linkwitz, "Improved Headphone Listening - Build a stereo-crossfeed circuit", Audio, December 1971
- [2] S.Linkwitz, [http://www.linkwitzlab.com/reference\\_earphones.htm](http://www.linkwitzlab.com/reference_earphones.htm) (etymot2.gif)
- [3] I.Ohrman, "Den Lilla Stereo-kontrollboxen SP12", Musik och Ljudteknik, Dec.1994; T.Kemhagen, [www.headwize.com/projects/showfile.php?file=kemhagen\\_prj.htm](http://www.headwize.com/projects/showfile.php?file=kemhagen_prj.htm) (kemhagen6.gif)
- [4] J.Meyer, [www.headwize.com/projects/showfile.php?file=meier\\_prj.htm](http://www.headwize.com/projects/showfile.php?file=meier_prj.htm) (meier6a.gif and meier6b.gif)
- [5] J.Conover, [www.johncon.com/johnr/SSheadphoneAmp/](http://www.johncon.com/johnr/SSheadphoneAmp/) (passive-small.jpg)
- [6] P.Millet, [www.pmillett.addr.com/ha-4\\_headphone\\_amp.htm](http://www.pmillett.addr.com/ha-4_headphone_amp.htm) (HA4PCB2.PDF)